

MODEL DDL-552-2 · 553-2 · 555-2
HIGH SPEED, SINGLE NEEDLE, LOCKSTITCH
INDUSTRIAL SEWING MACHINE
EQUIPPED WITH AN AUTOMATIC UNDERTRIMMER

MODEL DLN-415-2
HIGH SPEED, SINGLE NEEDLE, NEEDLE FEED,
LOCKSTITCH INDUSTRIAL SEWING MACHINE
EQUIPPED WITH AN AUTOMATIC UNDERTRIMMER

MODEL DLU-450-2
HIGH SPEED, SINGLE NEEDLE, TOP AND BOTTOM FEED
INDUSTRIAL SEWING MACHINE
EQUIPPED WITH AN AUTOMATIC UNDERTRIMMER

MODEL DLD-432-2
HIGH SPEED, SINGLE NEEDLE, DIFFERENTIAL FEED
INDUSTRIAL SEWING MACHINE
EQUIPPED WITH AN AUTOMATIC UNDERTRIMMER

INSTRUCTION BOOK

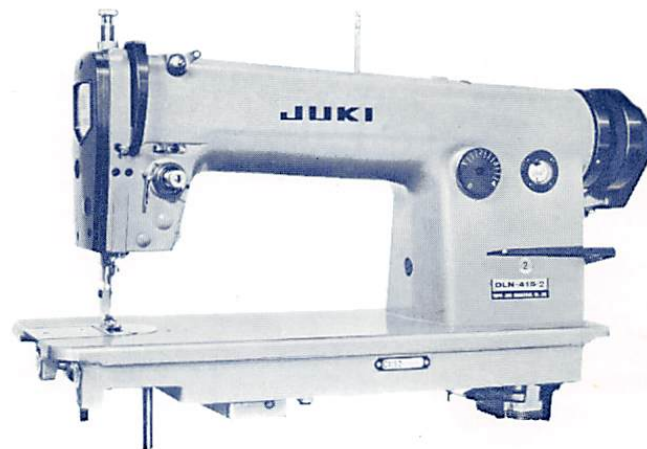
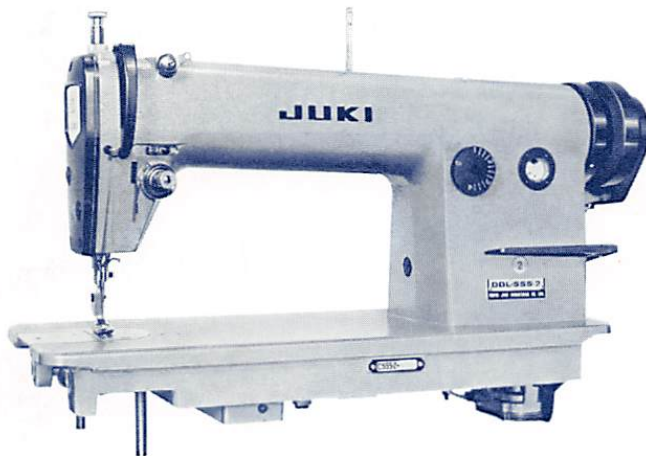

TOKYO JUKI INDUSTRIAL CO., LTD.

From the library of: Superior Sewing Machine & Supply LLC

CONTENTS

I.	GENERAL DESCRIPTION	1
1.	Outstanding features	1
2.	Main specifications	1
II.	HOW TO INSTALL THE MACHINE	2
1.	Table	2
2.	Installing the motor	2
3.	Limit of low-speed rotation of the machine	3
4.	Length of belt	3
5.	Installing the control box	3
6.	Installing the machine head	3
7.	Installing the pedal and its adjustment	4
8.	Construction and operation of motor lever switch	5
9.	Function of the cord	6
10.	How to handle the control box and cautions	9
11.	Adjusting the clutch gap	10
III.	HOW TO OPERATE THE MACHINE	11
1.	Caution on operation	11
2.	Lubrication and adjusting the oiling amount	11
3.	Trial run of the machine	11
4.	How to operate the pedal	12
5.	Threading the machine	13
6.	Adjusting the thread tension	13
7.	Adjusting the needle stop position after thread trimming	14
8.	When low speed sewing is not necessary	15
9.	Carefully note the following points	15
10.	How to select the presser foot, throat plate, sewing hook and feed dog	15
IV.	ADJUSTING THE MACHINE	16
1.	Adjusting the timing of the thread trimming cam	16
2.	Adjusting the position of the moving knife	17
3.	How to install the fixed knife correctly	18
4.	The floating range of the second thread tension disc	19
5.	How to sharpen the knife blade	20
6.	Changing the moving knife	20
7.	Adjusting the bobbin thread presser	21
8.	Adjusting the slide shaft	22
9.	How to install and remove the knife installing base	22
10.	Adjusting the installing angle of the synchronizer	23
11.	In case of electrical malfunctions	24
V.	DDL-552-2-3 DDL-552-2-4	25
	DDL-553-2-3 DDL-553-2-4	
	DDL-555-2-3 DDL-555-2-4	25
VI.	DDL-555-2-2B DDL-555-2-4B	27
VII.	MALFUNCTIONS AND CORRECTIVE MEASURES	28
VIII.	CIRCUIT DIAGRAM, TIME CHART	33
IX.	DIAGRAM SHOWING METHOD OF ASSEMBLING TABLE	35

I. GENERAL DESCRIPTION

1. Outstanding features

1) Simple operation

By a simple operation of one pedal, this machine will perform high speed sewing, low speed sewing, stopping and thread trimming with utmost ease. Also, as the thread trimmer is electrically controlled, all worries of operational tolerances are eliminated.

2) Stable efficiency

The thread trimming movement is interlocked with the rotation of the machine and controlled by electric device to produce constant, stable efficiency.

3) All attachments can be used without alterations

All attachments which are used for conventional lockstitch machines, such as feed dog, presser foot, needle plate, slide plate, etc. can be used on this machine without any alterations.

4) Dependable safety device

This machine is equipped with a dependable safety device by which the machine cannot be stepped on for high speed sewing until the thread trimming is completed after the thread trimming pedal is stepped on.

5) Compact construction

All the thread trimming mechanisms are built-in inside the bed in rational order so that the sewing area is amply wide and all attachments can be used freely.

2. Main specifications

Sewing speed	DLD-432-2 Up to 4,200 s.p.m.(Cotton) Up to 4,000 s.p.m.(Synthetic Fiber)
	DLU-450-2 Up to 4,200 s.p.m.(Cotton) Up to 4,000 s.p.m.(Synthetic Fiber)
	DLN-415-2 Up to 5,000 s.p.m.(Cotton) Up to 4,000 s.p.m.(Synthetic Fiber)
	DDL-555-2 Up to 5,000 s.p.m.(Cotton) Up to 4,000 s.p.m.(Synthetic Fiber)
	DDL-552-2 Up to 5,000 s.p.m.(Cotton) Up to 4,000 s.p.m.(Synthetic Fiber)
	DDL-553-2 Up to 4,300 s.p.m.
Low-speed rotation of the machine	Cotton thread Maximum 150 s.p.m. Synthetic thread Maximum 120 s.p.m.
Threads	Cotton, synthetic, silk
Sewing hook	DB type automatic lubricating hook with bobbin thread guide groove attached
Needles	DB x 1 DA x 1
Motor	Stop positioner clutch motor, 400W (Hitachi clutch motor with automatic needle positioner) AMCO motor Super stop motor
Electric control box	Voltage control DC 46V, DC 5V Voltage power AC 100, 115, 200, 240, 380, 415V (All ±10%) IC control system
Safety device	Built-in inside the motor lever

II. HOW TO INSTALL THE MACHINE

This machine is equipped with different kinds of devices than conventional lockstitching machines. All operations are controlled by the pedal and by the signals given out from the motor lever, the control box, with harmonious cooperation with the needle positioning synchronizer, thread trimming mechanism and the needle positioner clutch motor, the thread is neatly trimmed.

If the adjustment of the pedal is inadequate or if the connections of the cords are wrong, the machine will not function properly.

After the machine is properly installed, give it a trial run and verify the correct running of the machine.

1. Table

- 1) The installing positions of the table legs, motor and control box etc. are clearly illustrated by the dimensional diagram which is enclosed within this book.
 - 2) Fig.1 shows the rear view of the set-up.
- * The installed position of the control box is rather far away from the motor but this is for the purpose of removing the rear cover of the motor easier.

2. Installing the motor

- 1) Stop motor (automatic positioner stopping clutch motor) is used on this machine.
 - 2) Install the motor as shown in the dimensional diagram.
 - 3) The installation of the motor is same as any conventional lockstitching machine. (See Fig.2)
 - 4) The motor rotates toward the operator. (As viewed from the pulley side, the rotation is counter-clockwise)
- * Before installing the machine head, be sure to rotate the motor and verify its correct rotational direction.

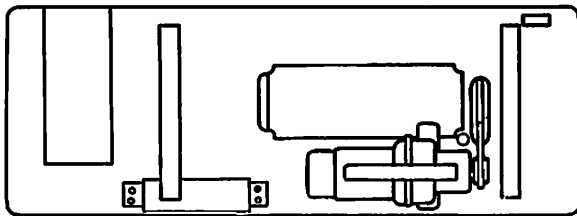

Fig. 1

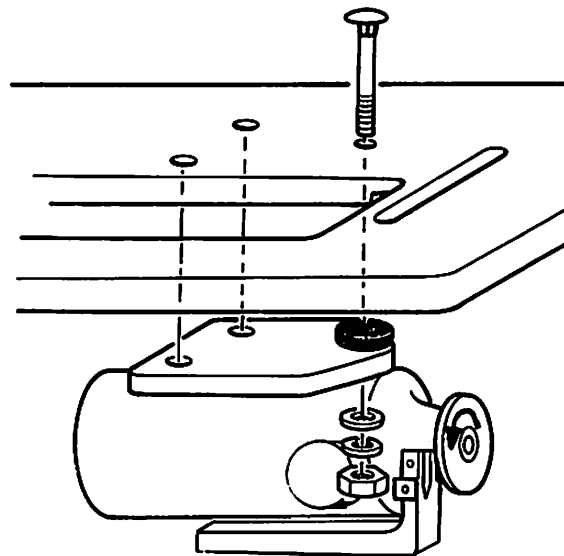

Fig. 2

3. Limit of low-speed rotation of the machine

For trimming the thread, the limit of low-speed rotation should be as follows:

For cotton threadUnder 150 s.p.m.

For synthetic thread.....Under 120 s.p.m.

1) With Hitachi, NATIONAL motor, when the high-speed rotation revolution number is determined, the low-speed revolution number is also set. Following table shows the relation between the size of the motor pulley with the high and low speed rotational number of revolution of the machine:

Outer dia. of motor pulley		125.5mm	116.5mm	105mm	95.5mm	90.5mm	81.0mm	76.0mm
50 cycle	High speed rotation	s.p.m. 5060	4630	4250	3820	3610	3390	
	Low speed Hitachi NATIONAL	s.p.m. 230	210	193	175	160	155	
60 cycle	High speed			5040	4540	4320	3790	3520
	Low speed Hitachi NATIONAL			228	206	193	173	160

4. Length of the belt

The length of the belt is shown in the table below:

Motor pulley Outer dia.		mm 125.5	116.5	95.5	90.5	81.0	76.0
Length of belt	For Hitachi Motors	43"	42"	42"	42"	41"	41"

*Note: Put on the belt before connecting the cord which is coming out from behind the hand wheel.

5. Installing the control box

Install the control box to the position as shown in the table dimensional diagram and tighten it with the screw as shown in Fig.3.

*Be sure to insert a rubber cushion, otherwise the movements of all electrical components will be impaired by vibration of the running machine.

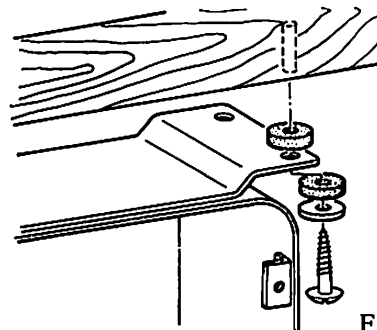

Fig. 3

6. Installing the machine head

The method of installing the machine head, oil reservoir, spool stand and the bobbin winder to the table is exactly identical with that of any conventional lockstitching machine.

7. Installing the pedal and its adjustment

In case of motor lever switch type, installation of the pedal and its adjustment is very simple.

1) 1) Installing position of the pedal

Fore and aft position of the pedal is adjusted by loosening the screw ① and left and right position is adjusted by loosening the screw ②. (Fig.4)

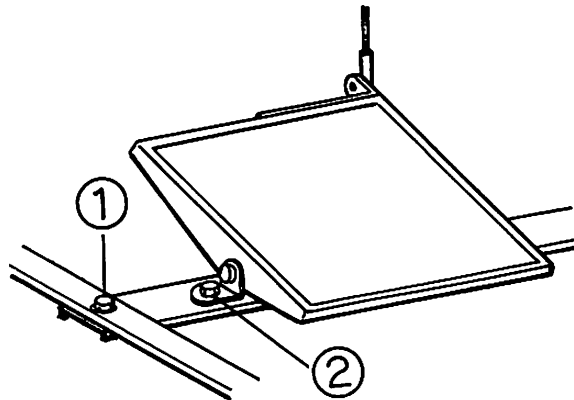

Fig. 4

2) Adjusting the angle of the pedal

This can be adjusted by just changing the length of the connecting bar as in the case of previous lockstitch machines.

Loosen the screw ③ of the coupling of the connecting bar and adjust by inserting and withdrawing the connecting bar. (Fig.5)

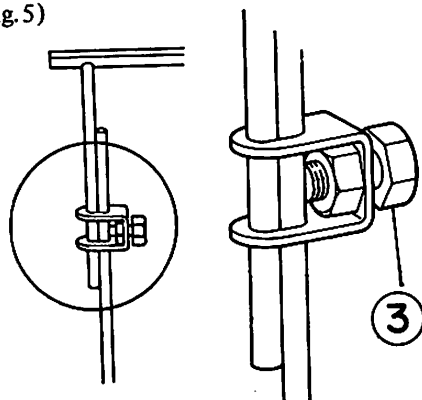

Fig. 5

3) Installing the connecting bar

Loosen the motor lever adjusting screw and adjust so that the motor lever and the connecting bar comes in straight line.

Also, be sure to securely tighten the nut of the connecting ball coupling so that it won't get loose.

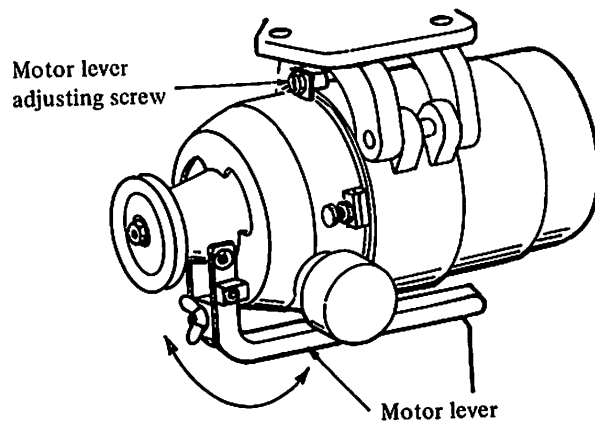
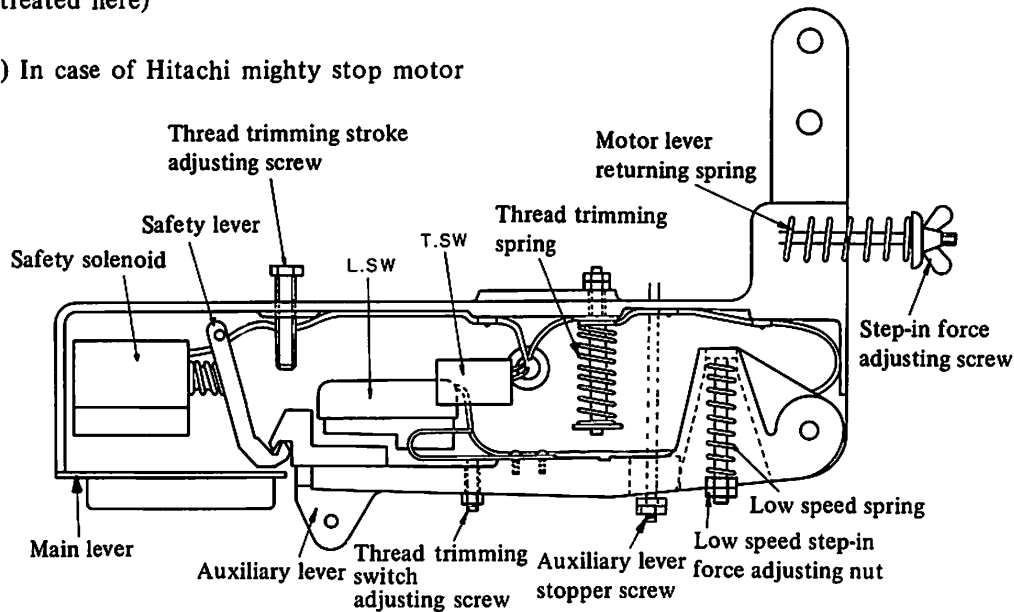

Fig. 6

8. Construction and operation of motor lever switch

(Full details are given in the Instruction Book of Hitachi and National Stop Motor, so it is lightly treated here)

1) In case of Hitachi mighty stop motor



Basically, this lever switch needs no adjustment. However, as there are 2-3 places which can be adjusted so adjust them in accordance with the following instructions.

Even if the pedal is stepped-in to the thread trimming position, the needle can not rise completely up due to the insufficient torque of the motor (when it stops during thread trimming operation) or when the machine does not stop at the designated position, tighten the step-in force adjusting screw. Please note that when this screw is tightened, the pedal pressure gets big when this is stepped-in to the high speed, so tighten lightly as long as there is no abnormalcy in thread trimming or machine stopping operations.

When the step-in returning amount at thread trimming is to be changed, the machine is so adjusted for easy step-in returning amount operation. However, when the machine is to be operated for the first time, sometimes it is easier to operate if the step-in returning amount at thread trimming time is increased. In such a case, return the thread trimming stroke adjusting screw within the area of 1~3mm(3/64~1/8"). At the same time, return the thread trimming switch adjusting screw and adjust so that T.S.W will activate at 1mm(3/64") before the auxiliary lever hits the thread trimming stroke adjusting screw and stops. After the adjustment, tightly tighten the locknut.

Do not adjust the low speed step-in force adjusting screw or auxiliary lever stopper spring. This lever switch is so assembled that even if the clutch lining of the motor is worn out, it is not necessary to readjust the position of the auxiliary lever stopper. When the low speed step-in force adjusting nut is screwed in and the pressure of the low speed sewing pedal is strenthened, the safety device activates and when the auxiliary lever hits the auxiliary lever stopper and stops, the main lever also moves to a certain degree with the force of the low speed spring.

Due to this action, there is a danger of the machine to keep on running at high speed and the possibility of the safety device unable to perform its role. After the machine is used for 1-2 days, the operator will get used to the machine, so do not try to readjust the step-in force at the time of low speed sewing.

If the machine can not run at high speed even if the safety device is not working, it is because the clutch lining is worn out. Exchange the lining with a new lining. If the position of the auxiliary lever stopper is not changed at the time of the new lining, it means the phenomenon is due to the abrasion of the clutch lining. It is better not to readjust the auxiliary lever stopper nut.

2) In case of National Pana Stop Motor

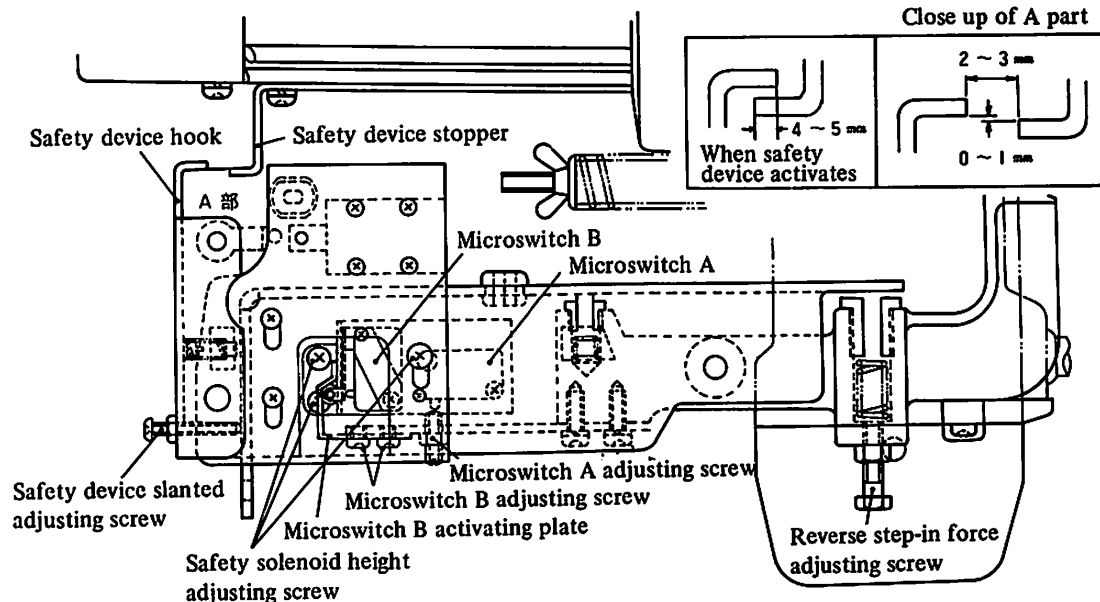

When the clearance of the clutch of the motor is to be adjusted or when the clutch friction plate and brake friction plate is to be exchanged, be sure to readjust the height of the stopper of the safety device. Loosen the installing screw of the safety device installing mount and adjust by moving the mount up and down. Make adjustment so that with the foot in released condition from the pedal, the clearance between the safety device stopper and upper and lower direction of the pawl of hook becomes 0~1 mm ($3/64''$), the horizontal direction becomes 2~3 mm ($5/64'' \sim 1/8''$) and that ① the safety device completely enters and ② when the safety device is in action, machine will not rotate even if the pedal is stepped in front.

Adjusting the reverse step-in force at thread trimming time

If the thread trimming step-in force adjusting screw is screwed in, this force gets stronger and if returned, it becomes weaker. After adjustment, tighten the locknut securely. The reverse step-in amount at the time of thread trimming is meaningless unless the installing position of the thread trimming switch must also be changed, so do not make adjustment.

Do not adjust the step-in pressure or the step-in amount of the low speed sewing.

This is because unless the adjustment is correctly made, the balance of force of low speed sewing and step-in force at thread trimming time and the reverse step-in force collapses and the machine becomes very difficult to operate.

For detailed information on the operation of Hitachi Mighty Stop Motor and the National Pana Stop Motor, refer to the respective Instruction Book and Engineers Manual for all operational procedures besides the above instructions.

9. Functions of the cord

The positions of the cords, which are coming out, depend on the kind of motors but the functions are same.

- ① This is the power source cord.
- ② This is the cord of motor for power source.
- ③ This is the cord of control box for power source. (3-pole plug)
- ④ This is the cord which transmits signals of low speed sewing or stopping from the control box to the motor. (9-pole plug)

- ⑤ This is the cord which transmits the signals of machine stopping position to the control box and also to activate the thread trimming magnet. The plugging color is white. (12-pole plug)
- ⑥ This is the cord which transmits the signal of thread trimming by means of pedal operation or low speed sewing to the control box and also to activate the safety device of the pedal. The plugging color is blue and this is plugged in to the control box front motor side. (9-pole plug)
- ⑦ This is the cord for the wiper and for automatic reverse sewing. It transmits the signal from the reverse sewing switch and activates the wiper (6-pole plug)

1) When HITACHI, NATIONAL motor is used (In case of motor lever switch system)

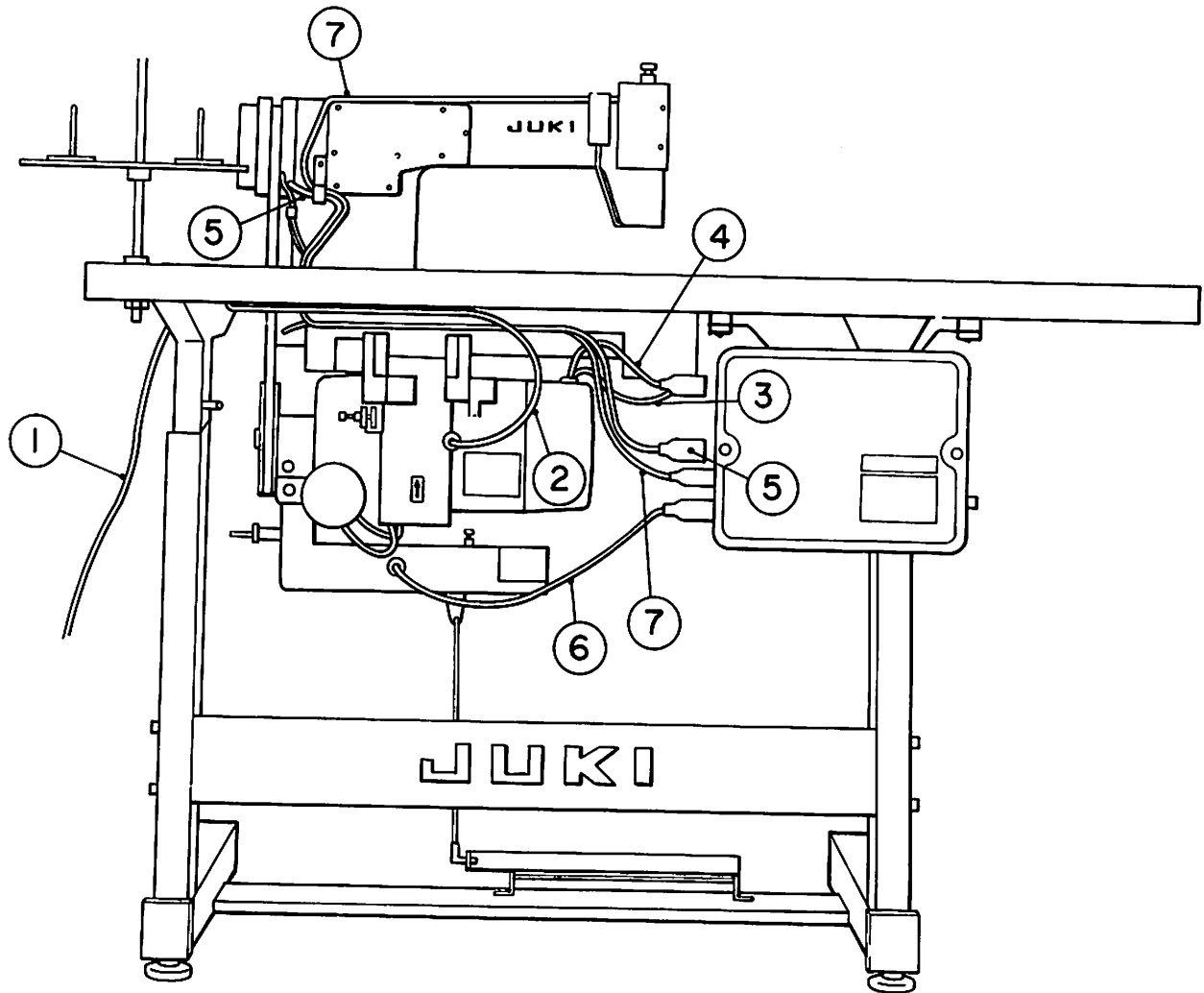

Fig. 7

2) Connecting the cords

A. How to connect the cord ⑤ coming out from the sensor

- * Plug-in the plug of cord ⑤ into the hole of the table.
- * As shown in Fig.8, hold the middle of this cord with the cord holder and cord support.
- * Lastly, plug-in the plug into the control box.
- * Be sure to press down the cord so that it won't touch the belt or the bobbin thread winder.

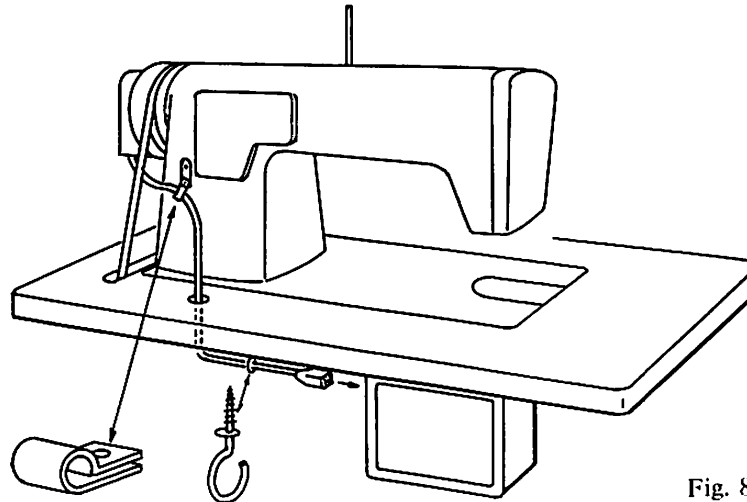

Fig. 8

B. How to connect the power source cord ③

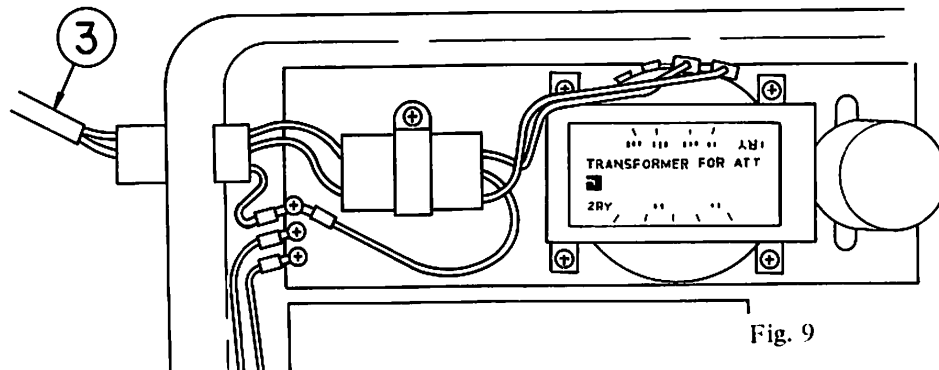

Fig. 9

a) In case of Hitachi and National motors (Fig.9)

- * The cord 3 coming out from the rear of the motor is the power source cord. Plug-in this plug to the plug socket on the side of the control box and connect them to the terminals on the left side of the transformer inside the control box.
- * Connect the white and black cords to the terminals of "0" and 200V. (White or black cord can be connected either to the "0" or 200V terminals. It doesn't matter)
- * With the 100V stop motor for single phase, connect them to the "0" and 100V terminals.

C. How to connect the cord ⑥ from the motor lever

Plug-in the cord, which is coming out from the motor lever, to the side part of the control box.

D. How to connect the cord ④ for controlling the motor

a) In case of Hitachi and National motors

Plug-in the black plug of the cord, which is coming out from the rear of the motor, into the black plug hole of the control box.

10. How to handle the control box and cautions

1) Wiring to the power source voltage and transformer

① Kinds of transformers and methods of connection

The side of the transformer on the power source side is called the primary side and according to the voltage used, four kinds of transformers, A, B, C and D are available.

A	100V, 115V
B	200V, 220V, 240V
C	380V, 415V
D	220V, 380V

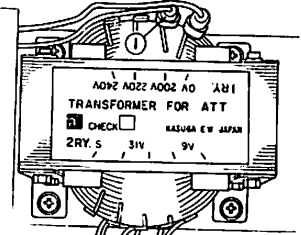

Be sure to connect the two electrical source leading wires to the "0" V of primary side and to the terminals ① which are of same voltage with the power source.

② Percentage of voltage variance

The limit of voltage variance is $\pm 10\%$. This control box is so constructed that even if the voltage is varied to the limit of 10%, it will function normally. When the voltage goes below the 10% limit, the timing of the magnet also changes, causing malfunctioning of the safety device. However, when the voltage gets too high, the life of diode, condenser, I.C. etc. will be shortened and sometimes the sensitive parts may be ruined, so be very careful.

2) Be sure to use fuses of 6A, 1A (Small) Amperes.

Even if the size of the glass tube is same, the running current may not be same. So be sure to use only the fuses marked as above.

In case the diode should break (in this case the current will run to any direction), or the wiring is wrong or if the circuit should be short-circuited, if the fuse of 6A is used, other electrical parts will not be damaged. If over-sized fuse is used, the damage will be felt by other parts also and the repairing will be a tremendous job.

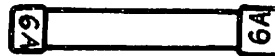

3) Correct connection of the ground wire (green)

There should be a ground terminal on the power source socket (for 3-phase, 4 plugs can be inserted), so be sure to connect this green ground wire to the 4 cords for the motor, the electrical equipment box and needle positioning synchronizer, correctly.

4) Do not damage the cords

When the 6-core cord coming out from the needle positioning synchronizer on the side of the hand wheel is touching the bobbin thread during the bobbin thread winding, the vinyl covering might be torn and might be short-circuited with the neighboring electric wire. If it touches the belt, the same contingency might result.

If any other cords are contacting any of the moving parts, there is always the danger of tearing these parts, so be sure to tie the cords firmly to the table or its legs.

5) When pulling out the plug of the electric equipment box, do not pull the cord strongly. This plug is so made to be pulled out easily. If you pull the cord too strongly, the copper wire and the tip of the pin terminal might come off.

6) The spare 6A fuse is attached to the control box with a red vinyl tape. In either case, when the fuse is blown out, exchange it just once. If it blows up again after replacing, there may be some trouble somewhere, so inspect the source of the trouble.

11. Adjusting the clutch gap

When the friction disc or brake friction disc begins to wear off, the motion of the lever gets bigger until the clutch is in and the stroke of the treadle gets more frequent and the operation becomes little difficult. When the movement of the tip of the lever becomes 15~20mm, adjust it as follows:

After loosening the set screw M6×10 ⑥ which is setting the brake, loosen the lock nut ③ which is setting the 2 bolts M6×30 ④.

Then, turn the the M6×30 ④ toward right (1mm per rotation), close in the clearance, and adjust so that the clearance becomes about 0.5~1mm. Judge this by moving the motor lever and watch the movement of the main shaft of the motor ⑦.

During this adjustment, repeat the in and out of the clutch by means of the motor lever and be careful to see that the brake friction disc does not lean to one side. After the adjustment, lightly push the lever toward the brake side and make the bolts M6×30 ④ contact the brake. Next, firmly tighten the set screw M6×10 ⑥ again and at the same time firmly set the lock nut which is setting the bolt M6×30 ④.

If the brake friction disk is slanted, it will emanate a peculiar crying sound. If this happens, insert the power source into the motor, and by repeating the in and out of the clutch, adjust the bolt M6×30. This sound will disappear,

Also, if the clearance is closed up, the brake must be put on while the main motor is rotating, inviting scorching of the motor or the fuse might be blown up. Be certain that the clearance is adjusted to 0.1~1mm always.

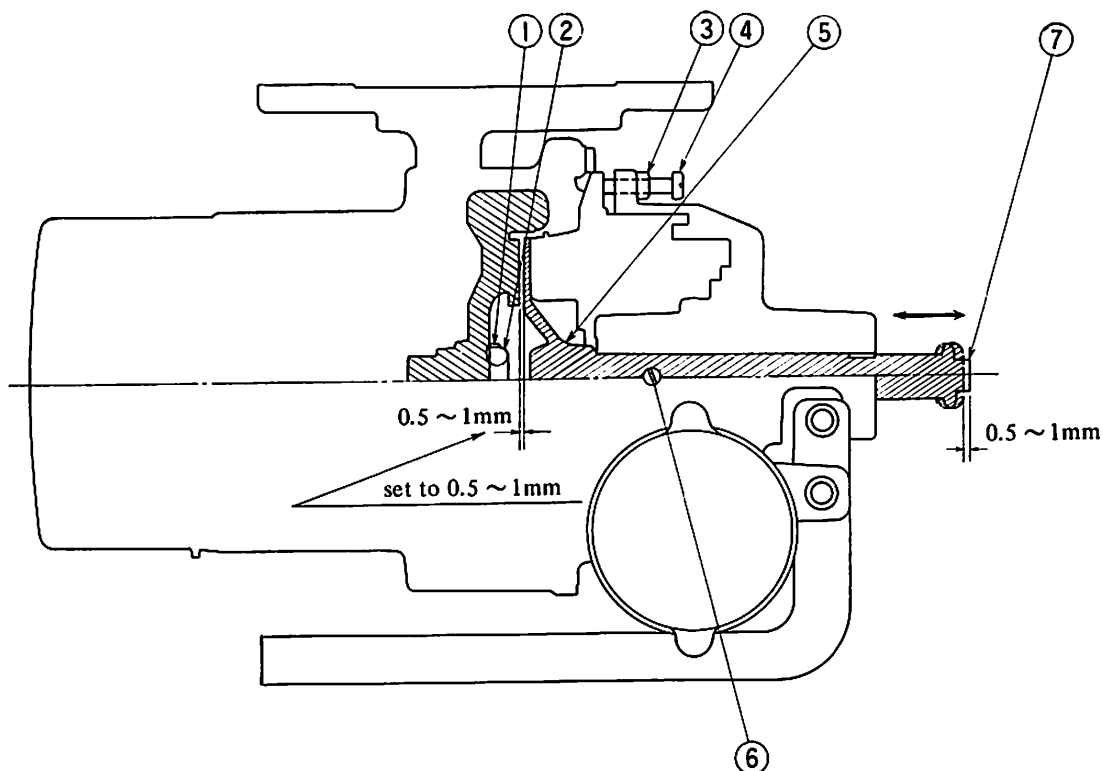

III. HOW TO OPERATE THE MACHINE

1. Cautions on operation

Turn the switch on once and after turning it off, step on the pedal and observe the rotational direction of the machine.

- * Unpack the machine and after setting it up, clean it well.
- * Before operating this machine, please read and digest every paragraph of the INSTRUCTION BOOK on DDL-552, 553 and 555 or DLN-415, DLU-450, DLD-432 thoroughly.
- * Do not run the machine without filling up the oil reservoir.
- * The machine should rotate toward the operator. (As viewed from the pulley side, the direction is counter-clockwise). Do not run the machine in the reverse direction.
- * For the first month, drop the speed to 4,500 s.p.m. for DDL-552-3 and DDL-555-3 and 4,300 s.p.m. for DLN-415-3 and 3,800 s.p.m. for DDL-553-3, DLU-450-3 and DLD-432-3. After that, increase the speed depending on the nature of work and the capability of the operator.
- * When the power switch is turned on, do not put your hands around and under the needle parts.
- * When the power switch is turned on, do not touch the hand wheel.
- * When the machine head has to be tilted for oiling or cleaning, be sure to turn the switch off.
- * If the needle does not stop at the top position even when the pedal is stepped on toward the rear, turn the switch off.
- * When transporting the machine, do not touch the cover on the rear part of the hand wheel.
- * Sometimes when the power switch is turned on and the thread is trimmed but if you step on the pedal to the rear immediately after these actions, the needle will not come down and trimming cannot be done. In such a case, just step on the pedal toward front once and the needle will come down and normal trimming can be resumed.

2. Lubrication and adjusting the oiling amount

Before running the machine, fill up the oil reservoir with the designated JUKI industrial machine oil to the "HIGH" mark. Please refer to the chapter on "Lubrication and drainage" on the separate instruction volume.

3. Trial run of the machine

- * At first, verify the correct movement of the machine without passing the thread.

1) When the power switch is turned on, the needle always stops at the raised position. In case the needle does not stop at the raised position, refer to the chapter on "Malfunctions and corrective measures" and make proper adjustment.

2) Step on the pedal lightly toward front and verify the correct low speed sewing operation.

If the machine does not function even after these re-adjustments, refer to the chapter on "Malfunctions and corrective measures".

3) After the pedal is stepped on front (away from the operator) and the foot is released, be sure to ascertain that the machine stops with the needle at lower position.

4) Step on the pedal toward rear and verify the thread trimming operation.

5) Re-adjusting the low-speed switch and verifying the correct working of the safety device.

Step on the pedal toward rear (the thread trimming switch will start) and if you hear the sound of the magnet working from under the bed, immediately step on the pedal toward front.

If these movements are repeated over and over again, invariably there will be a position where the pedal will not move toward front any more. At this position, the machine will be stopping but if the machine should move for low-speed sewing, re-adjust the low-speed sewing switch to stop the machine at this position.

6) Insert the needle and start sewing.

Note: *"Front" means away from the operator

*"Rear" means toward the operator

4. How to operate the pedal

As shown in Fig.10, the pedal of this machine functions in 4 stages as follows:

① The machine is stopping by just resting your foot lightly on the pedal.

② When the pedal is stepped on lightly to front, it becomes low-speed sewing.

③ When the pedal is stepped on further strongly to front, it becomes high speed sewing.

④ When the pedal is stepped on fully toward rear, the machine will perform thread trimming.

* Normal thread trimming can be performed even if the pedal is stepped on abruptly to the rear either from high speed or low speed sewing.

* After the machine has started the trimming, the trimming can be done even if the pedal is returned to the neutral position. It is not necessary to keep on stepping on the pedal to the rear until the needle goes up and stops.

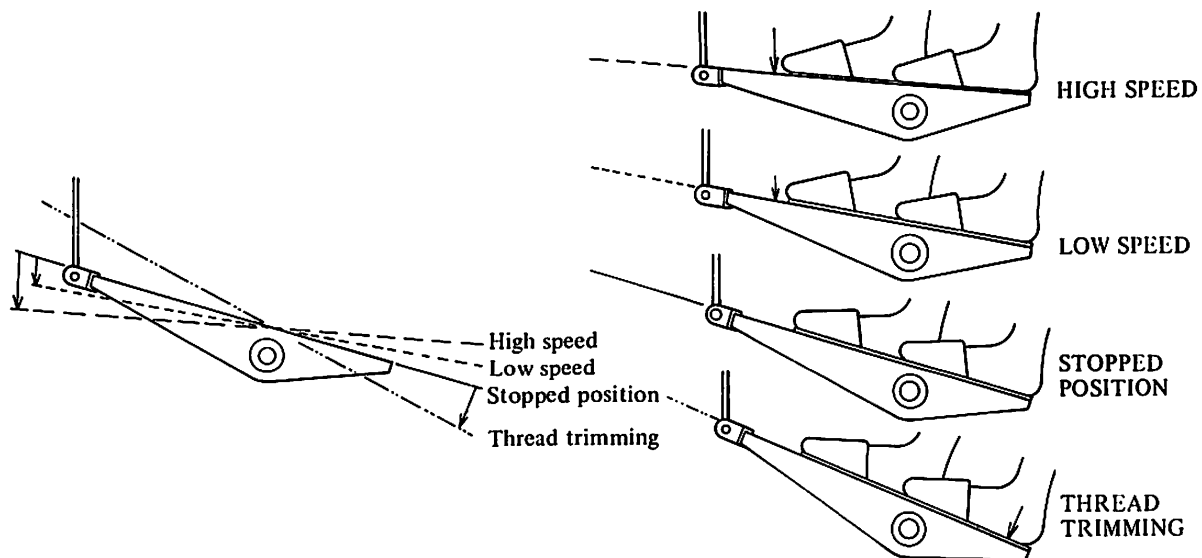

Fig. 10

- * When the machine is stopped, the needle always comes down and stops.
- * If the lowered needle is to be raised up again, step on the pedal toward rear fully. Needle goes up and stops after the trimming action.

(Caution)

After completing the trimming (stepping the pedal to rear), if you try to step on the pedal to front suddenly, sometimes the pedal will not move. This is because the safety device inside the pedal is acting to prevent any undue damage to the machine. In such a case, return the pedal to the rear once and then step on the pedal toward front once more and the machine will start its normal running.

5. Threading the machine

*The needle always stops at the raised position. But if it is at the lowered position when threading the machine, step on the pedal toward rear once and do the trimming action once. Then the needle will go up and stops there.

*Pass the needle thread in the order of ① ~ ⑫ as shown in Fig.27.

6. Adjusting the thread tension (Fig.28)

Adjusting the thread tension of this machine is exactly like a conventional lockstitching machine. Please follow the procedures as outlined in the INSTRUCTION BOOK on DDL-552, 553 and 555, DLN-415, DLU-450 or DLD-432. However, please note that due to the thread trimmer attached to this machine, the adjustment is little different than other lockstitch machines.

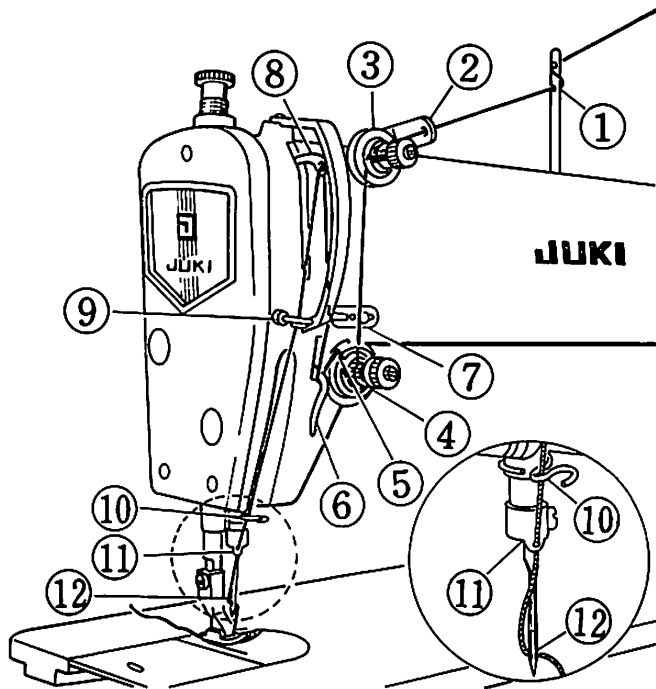

Fig. 11

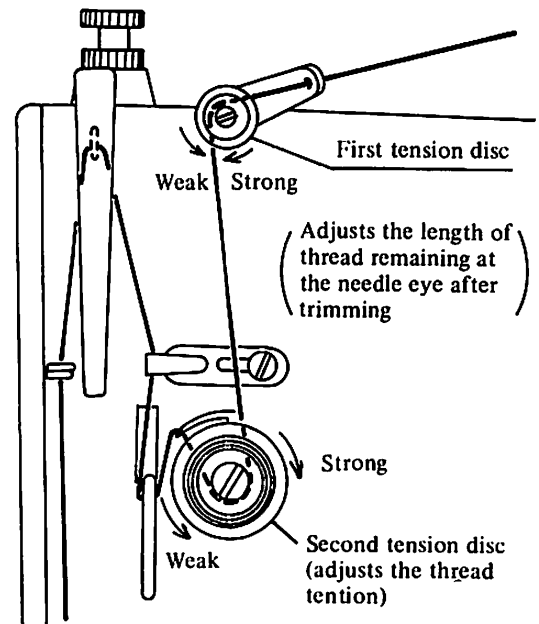

Fig. 12

1) Thread take-up spring

When fine cotton thread or synthetic threads (teton, nylon etc.) are used, the tension of the take-up spring may become too strong or the range of movement of the spring may become too wide, causing skip-stitching just before the machine stops and sometimes the machine does not trim the thread.

Be extremely careful.

2) Adjusting the first thread tension disc

*When the tension of the first thread tension is made stronger, the thread remaining at the tip of the needle eye becomes shorter after trimming and when it is made weaker, the remaining thread becomes longer.

*For fine threads (synthetic fiber), weaken the tension and for thick thread, make it stronger.

3) Adjusting the second thread tension

* Normally, the adjustment of this disc is same as any other lockstitching machines.

* However, please note that when synthetic thread is used, if the tension is adjusted too weak, the thread might break at the start of sewing.

4) Adjusting the bobbin thread tension.

The adjustment of the bobbin thread tension is practically same as any conventional lockstitching machine. However, if the tension is too weak, the bobbin might spin idly at the trimming instant, causing the needle thread to "float" up at the start of sewing, and for synthetic threads, thread breakage or slipping out of the needle thread at the start of sewing might occur. Be very careful.

* As a rule, this machine is used with a bobbin case in which a magnet is built-in to prevent idle spinning of the bobbin. (Part number is D 1837555 BAO and sold separately)

7. Adjusting the needle stop position after thread trimming (Fig.13)

After the thread is trimmed, this machine can change the needle stop position. To adjust to the standard needle stop position, rotate the needle position adjusting knob ① (on the side of the control box) to right and left so that, after the thread is trimmed and the needle has stopped, the red mark on the arm and the white mark on the hand wheel are matched with each other.

If the adjusting knob is rotated toward the "FAST" direction, the needle will stop above the standard stopping position (in case of A) and if it's rotated toward the "SLOW" direction, the needle will stop below the standard stopping position (in case of B).

* If the thread should slip out even if the length of needle thread is adjusted after the thread is trimmed, rotate the adjusting knob toward the "SLOW" direction. (toward [B] direction).

* If the needle should hit the wiper, rotate the knob toward the "FAST" direction. (toward [A] direction).

(Caution)

If the adjusting knob is rotated too much toward the "SLOW" direction (toward B direction), sometimes the machine does not stop. In such a case rotate the knob toward the "FAST" direction.

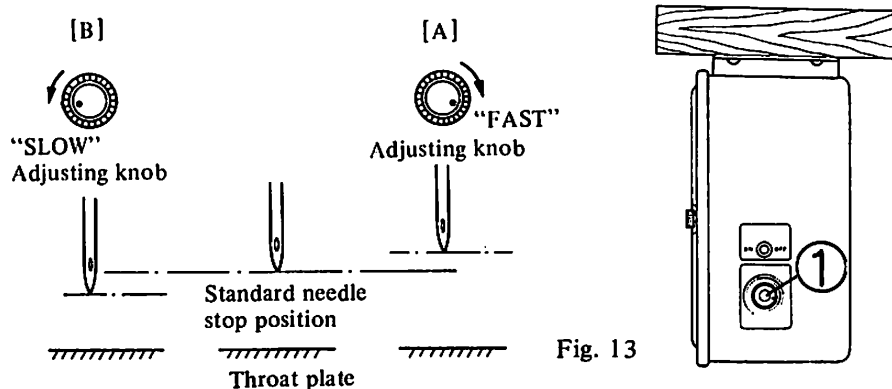

Fig. 13

8. When low speed sewing is not necessary (Fig.14)

* Be sure to cut off the power and make adjustment. When low speed sewing is not necessary at the start of sewing;

- ① Cut off the power source.
- ② Open the cover of the control box.
- ③ Pull out the inserted ① of the figure from the pin ④ and insert it into the pin ⑤.

Thus, the low speed sewing function can be eliminated without affecting the thread trimming function.

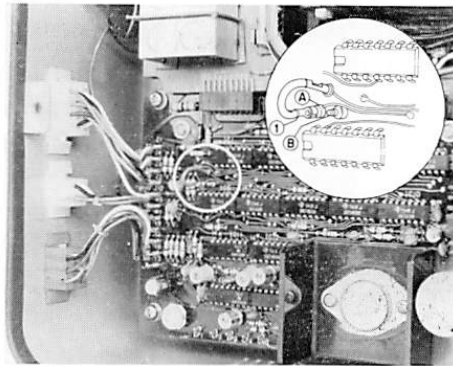

Fig. 14

9. Carefully note the following points

* Be certain that the needle thread comes out smoothly from the thread spindle. (Otherwise, the remaining thread at the needle eye after trimming will become short and thread slipping out might result.)

* When skip-stitching occurs, the bobbin thread may break but the needle thread does not break. In such a case, re-adjust the timing of the needle with the sewing hook.

10. How to select the presser foot, throat plate, sewing hook and feed dog

- 1) Presser foot Select small a and b parts (Fig.15)
- 2) Throat plate Select small needle eye and A part.
- 3) Needle Finer needle for less thread slippage
- 4) Sewing hook Automatic lubricating hook with a groove
- 5) Feed dog If a feed dog which is commonly used is adopted, there is no problem, but if an extremely thick feed dog is used, the backside of the dog teeth might be scratched when the moving knife moves fully.

1) Presser foot

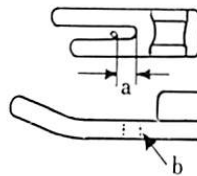

2) Throat plate

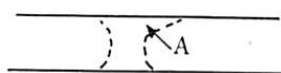

Fig. 15

IV. ADJUSTING THE MACHINE

This machine consists of lockstitching part and the thread trimming part. The lockstitching function is same as all other previous models, so this text will cover the thread trimming part only.

1. Adjusting the timing of the thread trimming cam

1) How to judge the correct timing of the trimming cam

In order to change the length of the thread remaining at the needle eye after trimming, adjust the timing of the thread trimming cam. This can be done easily by matching the arm with the indicated line on the hand wheel, according to the kind of thread used—cotton or synthetic thread.

Tilt the machine, turn the hand wheel with your hand until the thread take-up comes just before the upper dead point and if the sewing hook presser (Fig.16 ③) is pushed deeply to right, the cam roller (Fig.17) will enter the cam groove of the cam (Fig.17) and will be interlocked there. In that condition, rotate the hand wheel in the reverse direction than the conventional way, and the hand wheel will come to a point where it will not rotate any more. At this point if cam timing is matched so that the indicated line of the arm (Fig.18 ①) and the indicated line of the hand wheel (Fig.18 ②) are matched together as shown in Fig.18, it becomes a cotton thread timing. But if the indicating line (Fig.18 ①) is matched with the indicating line (Fig.18 ③), it becomes a timing for synthetic thread.

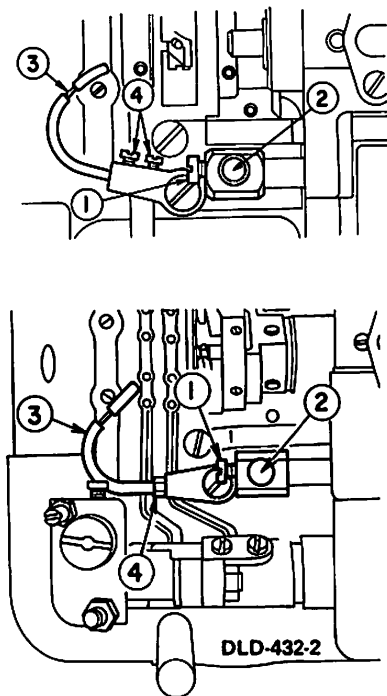

Fig. 16

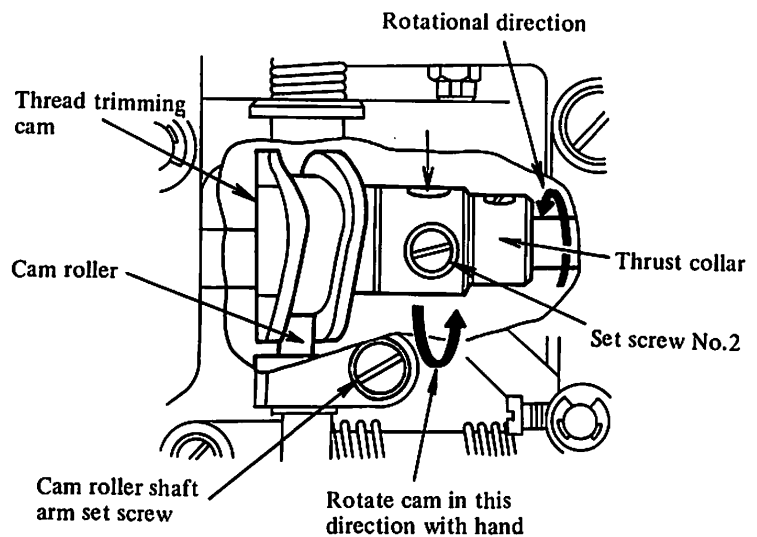

Fig. 17

2) How to match the timing of the thread trimming cam

First, loosen the 2 set screws of the trimming cam (Fig.17) in order from set screw No.1 and No.2, and match the indicating line of the arm with the indicating line of the hand wheel. (For cotton thread, match red color ① with the red color ② and for synthetic thread, red color ① with the green color ③), (Fig.18)

Then, by pushing the sewing hook presser (Fig.16 ③) to right, interlock the cam and the cam roller, and without rotating the hook shaft, rotate the cam only toward the reverse direction than the normal hook shaft rotational direction with your finger tips. At the position where the cam does not rotate any more, push the cam against the thread trimming cam thrust collar (Fig.17) and finally tighten the cam set screws (Fig.17) in the order of No.2 and No.1.

2. Adjusting the position of the moving knife

1) The correct position of the moving knife when it has moved to its maximum range is, as shown in Fig.19, when the tip of the moving knife has retreated to 2~2.5mm(1/6"~3/32") from the center of the needle. When the retreated range is less than this position, it cannot scoop up the needle or bobbin thread at the trimming instant, while if it's too much, the feed dog and the moving knife might hit each other. Therefore, it is very important to match the position of the moving knife correctly.

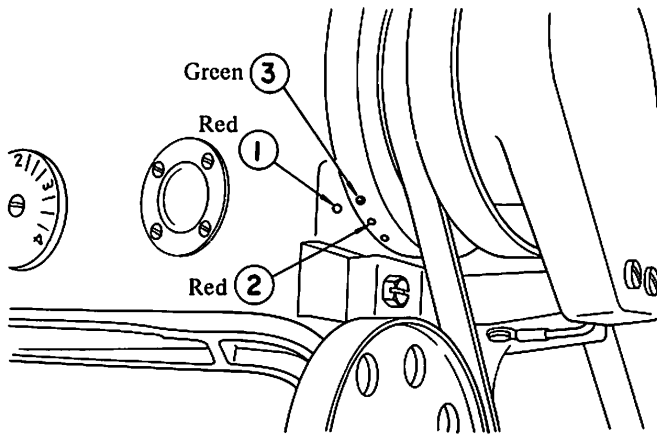

Fig. 18

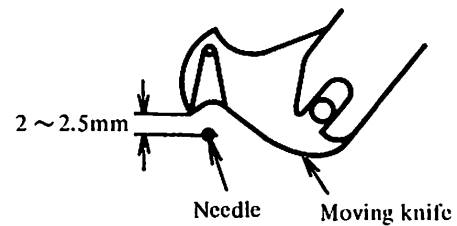

Fig. 19

2) How to match the position of the moving knife

This is adjusted by changing the right or left position of the moving knife shaft (Fig.20 ①) when the machine stops. By this adjustment, the interlocking of the cam and the cam roller also changes, so match the position of the thread trimming cam toward the shaft direction, also.

- a. First, loosen the magnet set screw (Fig.20 ②) and pull out the magnet link pin (Fig.20 ③).
- b. Move the magnet link (Fig.20 ④) downwards and adjust the screwed-in amount of the knife moving shaft adjusting nut (Fig.20 ⑤). If this nut is screwed in deep, the retreating range of the knife becomes greater and if it's loosened, the range gets less.
- c. Loosen both set screws of trimming cam ⑦ and the thrust collar ⑥.
- d. Match the indicating line of the hand wheel with the indicating line of the arm.
(In case of cotton thread, match ① with ② of Fig.18 and for synthetic thread, match ① with ③)
- e. Rotate the set screw No.2 (Fig.20 ⑧) (indicated point) of the trimming cam so that it comes to front and when it comes to front, push the sewing hook presser to right.
- f. Move the cam to right and left and interlock the cam and the cam roller.
- g. With this condition, as you pull the cam to right, move it toward the arrow direction until the cam cannot rotate anymore.
- h. Temporarily tighten the set screw No.2 ⑧ of the cam.
- i. Tighten the lock nut. (Fig.20 ⑤)
- j. At this point, verify the following:
 - ① Is the indicating line of the pulley matched?
 - ② Is the roller inserted smoothly into the cam groove?
 - ③ Is the retreated range of the moving knife 2~2.5mm?
- k. Tighten the two set screws of the cam securely.
- l. Push the thrust collar against the cam and tighten the two set screws.
- m. Attach the magnet link pin in its original position.

The simple method to judge the correct position of the moving knife would be to verify if the step part of the bed and the forked base of the knife are parallel to each other. If they are parallel, the position is correct.

(Note)

- 1) No matter how slight the right or left position adjustment may be, it has a big bearing on the retreating range of the moving knife.
- 2) Verify if the moving knife disposes the thread properly as shown in Fig.21.

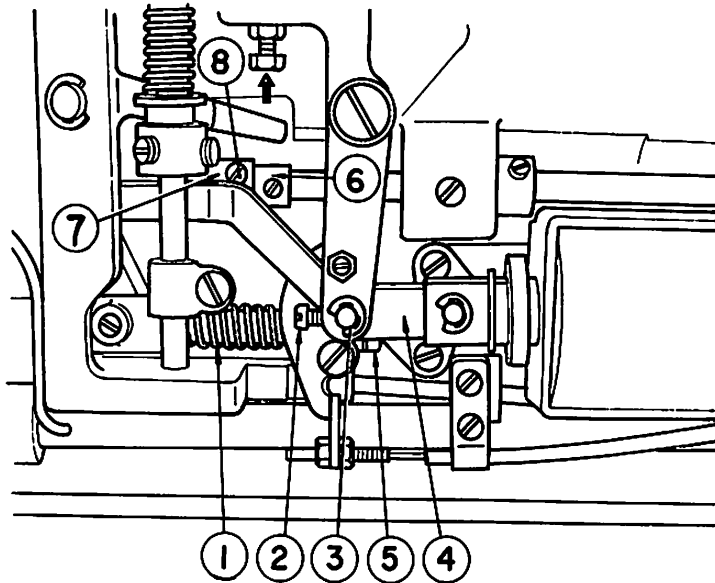

Fig. 20

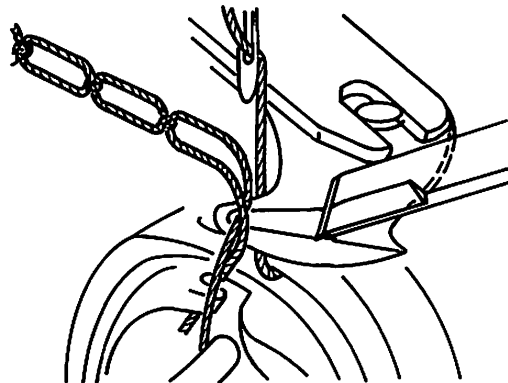

Fig. 21

3. How to install the fixed knife correctly

The correct method of installing the fixed knife is shown in Fig.22. The standard distance from the center of the needle to the tip of the fixed knife is 4.2mm(5/32"). The tip of the fixed knife should be 0.6mm above the installing surface. (Fig.23).

When the angle of the installing fixed knife's tip is changed, the cutting power changes. When the cutting part of the fixed knife and the moving knife is precisely matched, then and only then the cutting power becomes most powerful. When the fixed knife is to be adjusted or when it is to be changed, be sure to verify the sharpness of the blade and at the same time, adjust the angle of installation (Fig.22A).

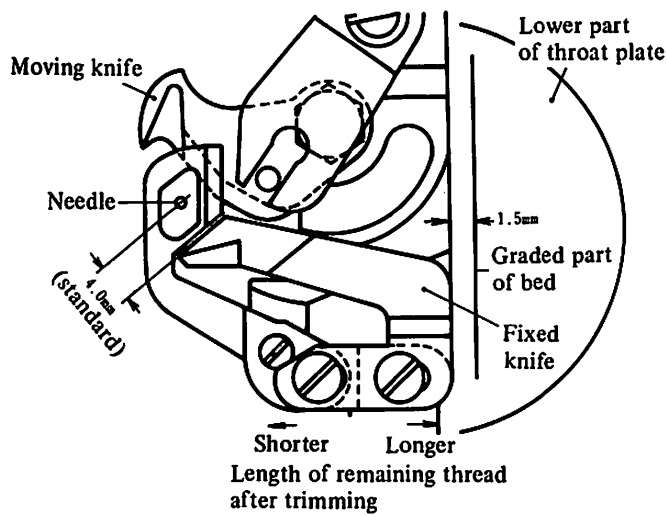

Fig. 22

(Note): DLN-415-2
Set the feed adjusting dial to "0".

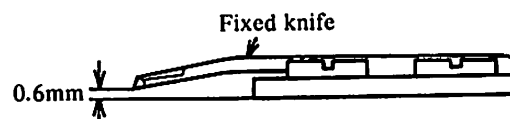

Fig. 23

- ⊙ The fixed knife can be installed by moving it to the right of the standard installation position.
- ⊙ In that case, the length of the remaining thread of needle thread and the bobbin thread not only gets longer by the distance the fixed knife has moved, but because the timing of the trimming also is delayed which makes the length of the thread at the tip of the needle eye much longer (Fig.25)
- ⊙ In the case of synthetic thread, move the fixed knife to right to delay the timing of the thread trimming. However, to make the adjustment complete, it is also necessary to adjust the timing of the thread trimmer. (Chapt. IV-1).

4. The floating range of the second thread tension disc

1) How to verify the floating range

At the position where the take-up has come just before the upper dead point, lower the presser foot and when the hook thread presser (Fig.16 ③) is pushed hard to right, verify that the floating range of the second thread tension disc is 0.5~1 mm.

2) Adjusting the floating range of the second thread tension disc (Fig.26)

① To increase the floating range, loosen nut ② and tighten nut ①.

② To decrease the floating range, loosen nut ① and tighten nut ②.

After the adjustment is completed, tighten both ① and ② nuts.

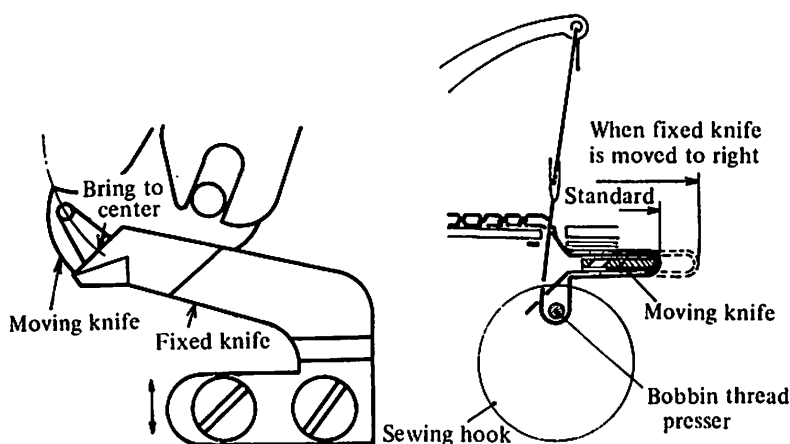

Fig. 24

Fig. 25

Fig. 26

5. How to sharpen the knife blade

The shape of the blade tip of the fixed knife greatly affects the cutting power of the knife. In most cases, just sharpen the blade of the fixed knife and the cutting becomes sharper.

1) It is very important that the blade surface of the moving knife should contact the blade of fixed knife.

- ⊙ Just sharpen the "A" surface (Fig.27) and cutting becomes better. (Note the angle shown by X in Fig.27)
- ⊙ The cutting power becomes weak when the B surface tip is sagging and blunted. So, do not change the angle of x when sharpening.
- ⊙ When cutting power is not so good even though the blade tips are sharpened, it is because the blade surface of the moving knife and the fixed knife is not contacting to right and left at the same time. Correct the inclination angle of the fixed knife.

* To improve the contacting of the moving and fixed knife, change the angle of the arrow mark of Fig.29. When the D side of Fig.28 does not cut well, shorten the angle and when the C side does not cut well, make the angle larger.

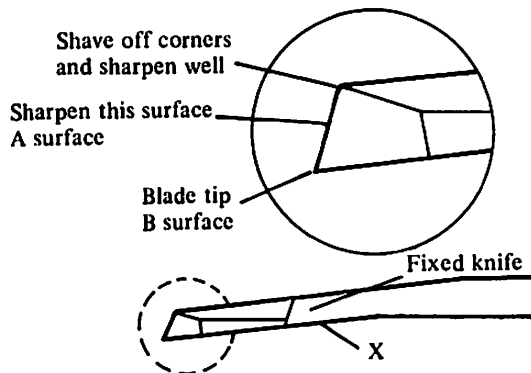
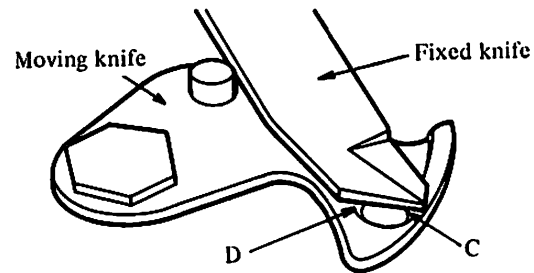

Fig. 27



C & D parts of moving knife and fixed knife should contact each other at the same time

Fig. 28

6. Changing the moving knife

To change the moving knife, do as follows:

- 1) Loosen the knife forked base pin set screw (Fig.32 ①) and pull out the knife forked base pin (Fig.32 ②).
- 2) Remove the moving knife hinge screw (Fig.30 ①), move the knife forked base (Fig.30 ②) and the moving knife (Fig.30 ③) to the position shown in Fig.31A and remove the pin of the moving knife from the knife forked base.
- 3) Move the knife forked base to the position shown in Fig.31B and remove the knife hinged screw (Fig.31B). For this purpose, use the special spanner in the accessories box.

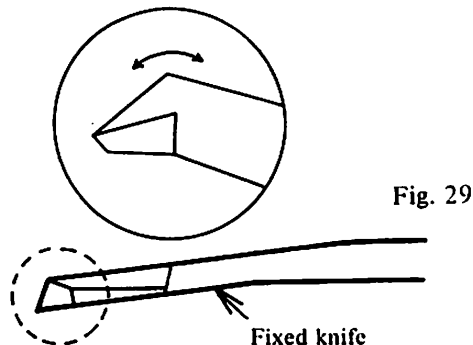

Fig. 29

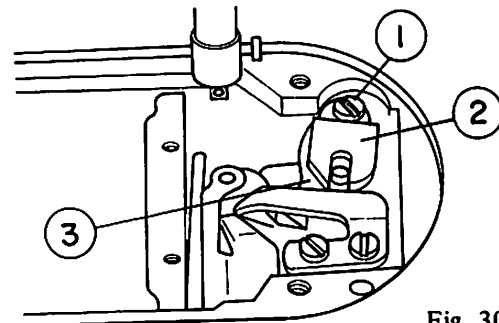
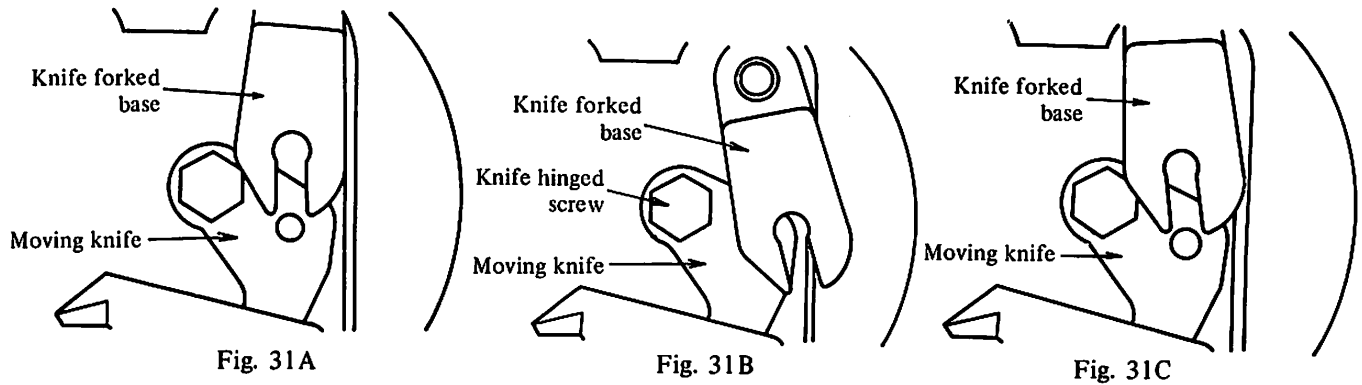

Fig. 30

For installing back, reverse the above procedure. After the knife hinged screw is tightened, move the moving knife with your hand and see if it moves smoothly without any rattling. Match the knife forked base to the position shown in Fig.31C and firmly insert the knife forked base pin into the forked base. (If the knife moving shaft is moved to right or left, the pin will go in deep into the base). When the shaft is moved to right, be sure to see that the knife moves to right, also.



7. Adjusting the bobbin thread presser

If the bobbin thread presser (Fig.32 ③) is penetrating too deep toward the bobbin case at the trimming time, the bobbin will not rotate and the bobbin thread will be trimmed too short, causing thread slippage at the start of sewing.

On the contrary, if it is not inserted deep enough, the needle thread will slip out from the tip of the bobbin thread presser at the trimming time, shortening the thread remaining amount at the tip of the needle eye after the trimming and invites thread slipping out.

1) The correct position of the bobbin thread presser

When the thread trimming lever is pressed hard against the stopper side, the bobbin thread should be pulled out easily. At this position, the clearance between the tip (Bobbin presser) of the bobbin thread presser and the upper carved part of the bobbin should be 1.5~2mm as shown in Fig.47.

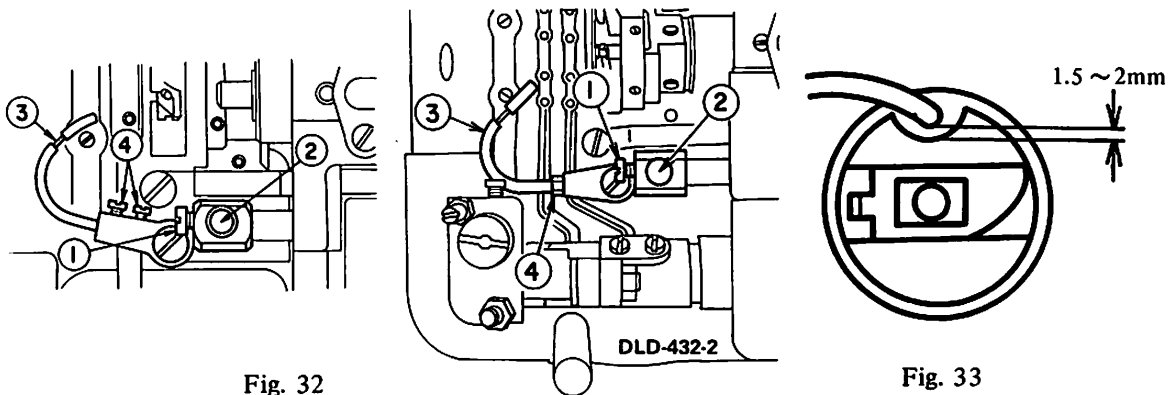

2) How to adjust the bobbin thread presser

Loosen the screws (Fig.32 ④), and adjust by moving the bobbin thread presser in and out or up and down. At this instant, adjust the fore and aft position of the bobbin thread presser and adjusting the position of the thread trimming stopper arm (Fig.26 ②). As shown in figure.

After adjusting, tighten the set screw of the stopper. Be sure to verify that the tip of the roller shaft is not contacting the bottom of the cam groove when the stopper is deeply inserted. If it's contacting, refer to the chapter on "Adjusting the slide shaft" and re-adjust the position of the slide shaft collar.

8. Adjusting the slide shaft

The moving range of the slide shaft (Fig.34 ①) is 5.4mm(7/32"). This is adjusted by moving the slide collar (Fig.34 ②) toward the shaft direction. Also, the position of the cam roller shaft arm (Fig.34 ③) should be 13.5mm(33/64") as shown in Fig.34.

* The adjusting procedure is as follows:

① Determine the position of the thread trimming arm stopper depending upon the position of the hook thread presser.

② Adjust the position of the slide collar so that the moving range of the slide shaft comes to 5.5mm(7/32").

③ Adjust the position of the thread trimmer magnet (DC solenoid).

When the thread trimming arm has moved to the position where it is almost touching the stopper, adjust the position of the thread trimming magnet so that the snap ring which is attached to the thread trimming magnet plunger hits the rubber ring and stops and also when the magnet is pulling, there should be no clearance between the two ends of the rubber ring.

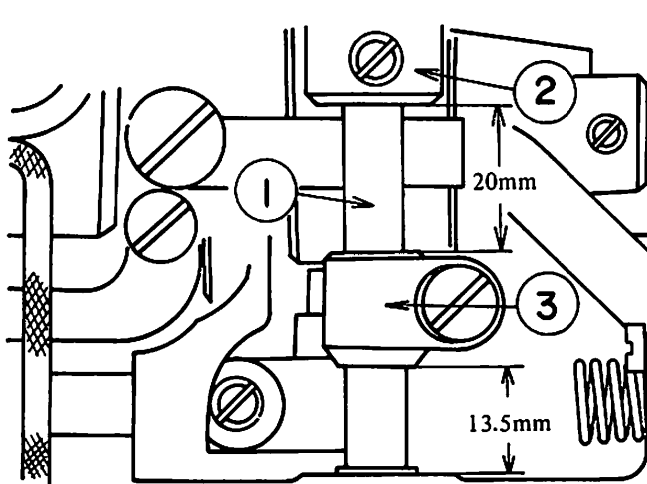

Fig. 34

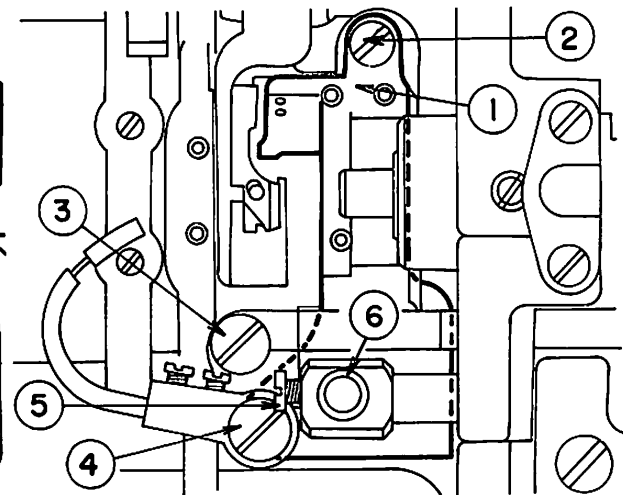

Fig. 35

9. How to install and remove the knife installing base

To remove the knife installing base (Fig.35 ①), do as follows in order:

① Take out the sewing hook.

② Loosen the knife forked base (Fig.35 ⑤), and pull out the knife forked base pin (Fig.35 ⑥).

③ After removing the hook thread presser link hinged screw (Fig.35 ③), and if the hook presser hinged screw (Fig.35 ④) knife installing base set screw (Fig.35 ②) is pulled out, the knife installing base will come off. To install back, reverse this order.

10. Adjusting the position of the synchronizer (Fig.36)

This synchronizer has adopted semi-leading element, non-contacting type called hole IC, so it is impossible to verify the position of the synchronizer by the tester by pulling out the 12P plug. Therefore, the position of the synchronizer should be adjusted in the following order:

- ① Remove the belt.
- ② Remove the cover ① of the synchronizer and loosen the screw ④.
- ③ Turn the power source switch to "ON".
- ④ Match the black indicating line of the pulley with the red indicating line of the machine head.
- ⑤ If the synchronizer is moved gently by the hand without moving the pulley, the auxiliary motor will either rotate or stop. So, at the position where the auxiliary motor has started to stop, tighten the screw ④.
- ⑥ Replace the cover of the synchronizer to the original position.

(Note) When the above adjustments are made, do not loosen the screw ⑤ (+ screw), absolutely. If this part is either loosened or released, sometimes the synchronizer does not function. So, use extreme caution.

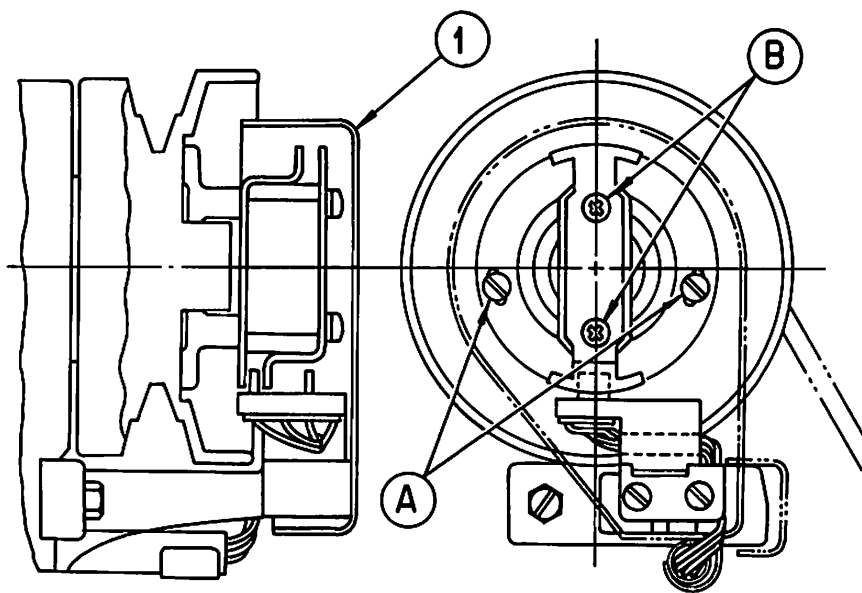

Fig. 36

11. In case of electrical malfunctions, be sure to investigate the following discrepancies: (Refer to malfunctions and corrective measures for complete details)

No.	Malfunctions	Causes	Corrective measures
1	Does not run at low speed	<ol style="list-style-type: none"> 1. Defective L.SW switch. 2. Motor cord is pulled out (does not stop at upper stop position). 3. Inadequate plug-in of bi-directional-triode thyristor printed board. 4. Wire of auxiliary motor is disconnected. 5. Inadequate returning of MB clutch part. 6. Low speed function changing pin is connected to the low speed (off) side. (Inside the control box). 	<ul style="list-style-type: none"> * Exchange the L.SW switch. * Plug-in correctly. * Plug-in correctly. * Connector inside the motor (end cover) is disconnected. * Repair the clutch part with oil stone. * Replug-in the pin to the "on" side.
2	Main motor is over-heated	<ol style="list-style-type: none"> 1. No clearance at clutch part. 2. One phase of 3 phases is disconnected (single phase running). 	<ul style="list-style-type: none"> * Adjust the clearance of clutch part. * Inspect the plug-in condition of the power source cord. (Verify the fuse of the power source of the plant)
3	Auxiliary motor is over-heated	<ol style="list-style-type: none"> 1. Inadequate returning of the MB part. 2. Inadequate lead relay (contact point) 3. One phase of 3 phases is disconnected. 	<ul style="list-style-type: none"> * Repair the clutch part with oil stone. * Exchange the lead relay. * Connector inside the motor (end cover) is disconnected.
4	Enters into low speed running with the power source "ON".	<ol style="list-style-type: none"> 1. Inadequate position of L.SW switch. 2. Defective L.SW switch. 3. 12P connector of head is pulled out. 4. Inadequate adjustment of the adjusting knob of stopping position. 5. Pedal cord is pulled out (make it to upper stopping position). 	<ul style="list-style-type: none"> * Adjust the position of L.SW switch. * Exchange the L.SW switch. * Re-plug-in the connector. * Rotate the knob toward the "FAST" direction. * Re-plug-in the connector.
5	Machine does not stop (keeps on running at low speed)	<ol style="list-style-type: none"> 1. Defective L.SW switch. 2. Too much clearance of magnet brake. 3. 6A fuse is blown out. 4. Pressure of returning spring of motor lever is too weak. 5. 12P connector of head is pulled out. 	<ul style="list-style-type: none"> * Exchange the L.SW switch. * Re-adjust the clearance. * Exchange the 6A fuse. * Tighten the adjusting screw. * Re-plug-in correctly.
6	Does not rotate at low speed. Thread trimming not performed and stops at any position.	<ol style="list-style-type: none"> 1. 1A fuse is blown out. 	<ul style="list-style-type: none"> * Exchange the 1A fuse.

V. HIGH SPEED, SINGLE NEEDLE, LOCKSTITCH, AUTOMATIC UNDERTRIMMER EQUIPPED WITH A WIPER

Model DDL-552-2-3 DDL-552-2-4
 DDL-553-2-3 DDL-553-2-4
 DDL-555-2-3 DDL-555-2-4

1. Adjusting the position of the wiper

The position of the wiper is adjusted according to the thickness of the sewing cloth. Normally, adjust it as follows:

1) Rotate the hand wheel toward the regular direction and as shown in Fig.37, bring the white point ① of the hand wheel so that it will match with the red point ② of the frame.

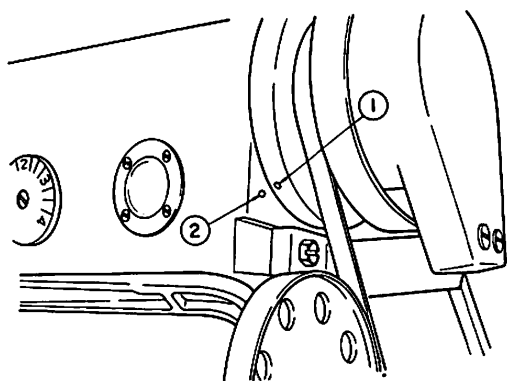

Fig. 37

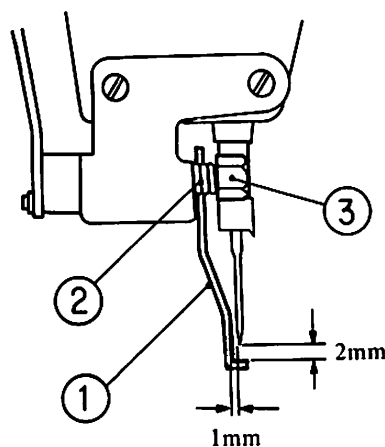

Fig. 38

2) Then, as shown in Fig.38, insert the wiper ① into the driving shaft ② and bring the tip of the wiper so that it will come to 2mm (approx. 1/16") under the point of the needle. Make sure that the space between the flat surface of the wiper and the center of the needle comes to 1mm (approx. 5/128").

2. Adjusting the position of the wiper magnet

1) Pull in the plunger entirely into the coil, loosen the wiper magnet set screw ① and by moving the wiper magnet up and down and as shown in Fig.3, adjust so that the edge of the wiper comes to the position where it will be away from the needle center by 2mm (approx. 1/16"). After this adjustment, securely tighten the wiper magnet set screw.

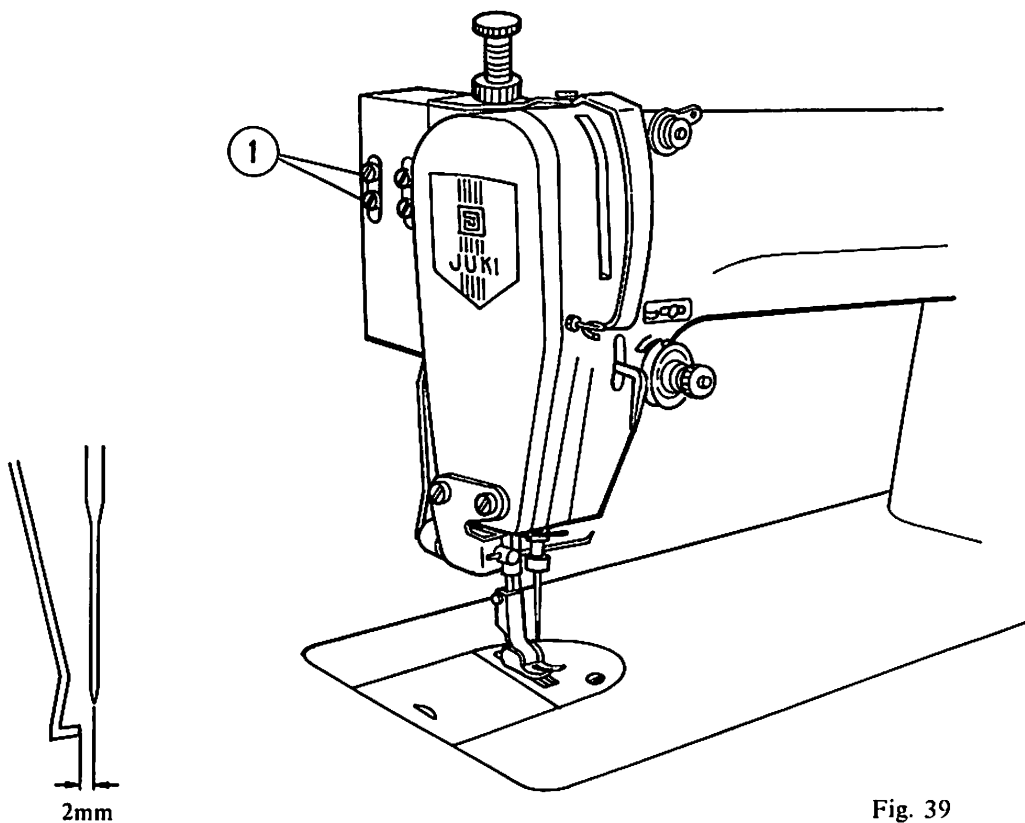

Fig. 39

* With the exception of above, all operating instructions and adjustments are same as DDL-555-2.

VI. HIGH SPEED, SINGLE NEEDLE, LOCKSTITCH INDUSTRIAL SEWING MACHINES WITH AUTOMATIC THREAD TRIMMER AND AUTOMATIC REVERSE SEWING UNIT

Model DDL-555-2-2B DDL-555-2-4B

1. How to sew automatically

- ① If the push button ① is pushed, the machine will become in reverse sewing state and reverse sewing can be performed.
- ② As long as this button is kept pressed, the machine will do reverse sewing.
- ③ If the button is released, the machine will return to normal sewing condition.
- ④ When half-stitching process is to be performed, use the normal back lever.

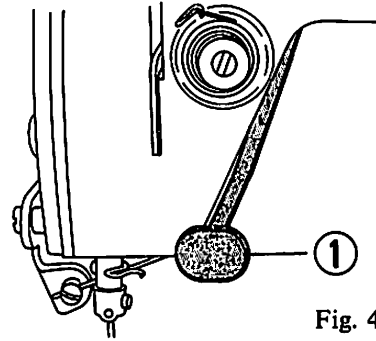

Fig. 40

2. Adjusting the switch lever of reverse sewing

- ① The height of the push button ① is not specially set, so adjust it to an appropriate position.
- ② Loosen screw ②, move the push button up and down and adjust to the proper height. After adjustment, securely tighten the screws.

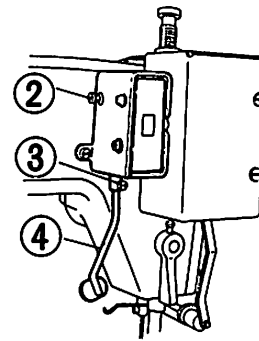

Fig. 41

3. Adjusting the pitch of reverse sewing

Due to the adoption of push button system, until the operator gets used to the system, sometimes the length of the reverse sewing might become longer than necessary.

In case when the pitch of the reverse sewing may be lessened than the normal sewing, do as follows and the pitch of the reverse sewing will become smaller and accordingly the length of the reverse sewing will become shorter.

Loosen the screw ① from the bottom of the bed and raise up the stopper ② and the pitch of reverse sewing will become less. If this is lowered fully to bottom, the pitches of the normal feed and the reverse sewing will become same.

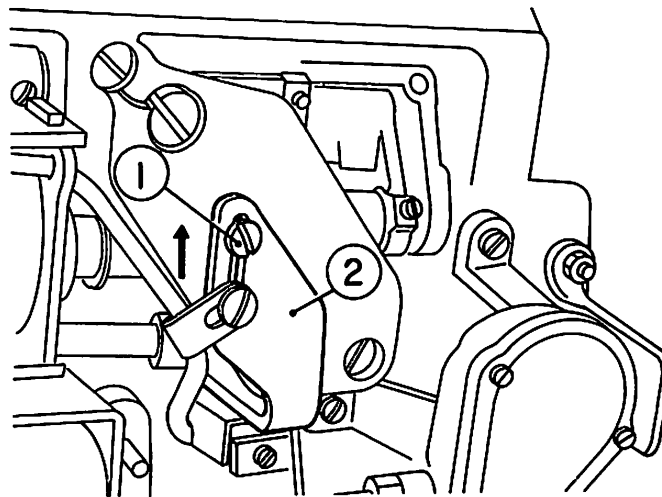

Fig. 42

* With the exception of above, all operating instructions and adjustments are same as DDL-555-2, Please refer to INSTRUCTION BOOK on DDL-552, 553, 555.

VII. MALFUNCTIONS AND CORRECTIVE MEASURES

Malfunctions	Causes	Order of Inspection and Corrective Measures
A. 1-several stitches skip at start of sewing	1. Thread remaining at the needle eye after thread trimming is too short	<ul style="list-style-type: none"> ① Inspect the needle thread route, correct idle spinning of thread from thread guide rod and position of thread guide of the thread stand. ② Rotate the thread adjusting nut of the first tension disc to left and weaken the tension. ③ Check and see if the floating range of the second tension disc is 0.5mm~1mm (1/64"~3/64") when the bobbin presser is pushed in to right and adjust by the adjusting nut under the bed (Refer IV-4). Also see if the disc is loosened evenly, horizontally, and if not, either rotate the tension spring 180° or change the slant of the spring. ④ Follow IV-1 and adjust cam timing. ⑤ Inspect the loose condition of bobbin thread presser set screw (IV-7). ⑥ Remove the needle plate, inspect the position of the fixed knife and adjust any bruise of moving knife (IV-3, IV-6). ⑦ Inspect the bruised condition of the sewing hook and knife thread guide hole. If any bruises are found, thoroughly polish with buff, etc. If the bruises are serious, change the parts.
	2. The needle, needle plate and presser foot used are inadequate or the pressing power is too weak	<ul style="list-style-type: none"> ① Inspect the shaping of "a" and "b" part of presser foot and "A" part of needle plate. <ul style="list-style-type: none"> a. When using synthetic thread on tricot material. a < 0.8mm b & A part r < 0.3mm b. When synthetic thread is used, a 1.2mm, b & A part without grooves. c. For cotton thread too, as long as no defective thread tightening, a, b, A parts should have small grooves. d. The finer the cloth, more mesh the cloth, the more slippery the thread, the smaller the stitch pitch, the grooves of a, b, A parts should be small. ② As long as the thread tightening is not defective, use a finer needle. Use #7 ~ #9 needles especially for tricot material ③ If pressing power is too weak, adjust by the presser foot adjusting screw.
	3. Hook point does not scoop up the needle thread (skip-stitching)	<ul style="list-style-type: none"> ① Run the machine at low speed and if skip-stitch is verified, correct the angle of the needle and its curvature. ② Try decreasing the spring power of the take-up spring and its range of movement to 5~7mm(3/16~1/4"). ③ Make the timing of hook faster than normal lockstitching machine. Make clearance less than 0.05mm(1/512").
	4. The bobbin thread is too short at the start of sewing	<ul style="list-style-type: none"> ① After the thread is trimmed, take out the bobbin case and if the idle spinning of the bobbin is too much: <ul style="list-style-type: none"> a. Make the pressure of the bobbin presser stronger. (Refer to IV-7). b. Check the tension of the bobbin thread. Conduct the above inspection and make the length of the bobbin thread to 35~50mm(1-3/8~1-31/32"). <ul style="list-style-type: none"> ② After the thread is trimmed, if there is no idle spinning of the bobbin and the thread is trimmed short, make the pressure of the bobbin presser weaker. (Refer to IV-7). ③ Polish the sewing hook or exchange it.
B. Needle thread slips out from the needle at the start of sewing	5. The length of needle thread after trimming is scattered	<ul style="list-style-type: none"> ① Stop the motor and at the position where the needle is lowered, insert the hook presser into the bobbin case. Rotate the hand wheel with your hand, trim the thread and stop the machine at the upper dead point. At this instant if the needle thread remaining at the tip of the needle eye is more than 10mm(3/8") shorter than when trimmed by pedal action, this means a "intermediate" cutting. <ul style="list-style-type: none"> a. So, quicken the cam timing and weaken the first thread tension. b. Sharpen the fixed knife again correctly. (IV-5). c. Polish the knife thread guide, moving knife and the sewing hook thoroughly.

From the library of: Superior Sewing Machine & Supply LLC

Malfunctions	Causes		Order of Inspection and Corrective Measures
Needle thread slips out from the needle immediately after trimming		<ul style="list-style-type: none"> The fixed knife is too sharp (too pointed at top) cutting the thread only with the fixed knife Knife thread guide, moving knife and hook are bruised Cam timing is too fast so even the needle thread on the side of the needle is trimmed also Needle is too thick 	<ol style="list-style-type: none"> When the length is less than 20mm(25/32"), adjust the position of the bobbin presser (IV-7). When the needle thread breaks just after trimming, this is because the needle thread remaining at the side of the needle is being cut due to the inadequate disposition of the thread by the moving knife. When the needle plate is removed, about 20mm(25/32") of the needle thread is remaining. In such a case, delay the timing of the cam (IV-1).
C. At the start of sewing, the tip of needle thread sticks out atop the cloth	1. The needle thread remaining at the needle eye after thread trimming is too long	<ul style="list-style-type: none"> The first tension disc tension is too weak Cam timing is too late The fixed knife is retreated too far 	<ol style="list-style-type: none"> Try strengthen the first tension disc (IV-2). Try bring the fixed knife closer to the needle (IV-3). Try quickening the cam timing (IV-1).
D. The back side of the cloth is dirty at the start of sewing (Long needle thread is remaining under the cloth)	<ol style="list-style-type: none"> The needle thread remaining at needle eye after trimming is too long Needle, needle plate and presser foot inadequate and after trimming, cannot shorten the remaining needle thread at needle tip 	(Please refer to previous chapters)	<ol style="list-style-type: none"> Refer to previous chapter. Refer to 1-2 chapter on "Malfunctions and corrective measures" and make proper adjustments.
E. Thread tension is bad at start of sewing	1. The needle thread tension at start of sewing too weak	<ul style="list-style-type: none"> Inadequate installation of bobbin presser. Due to idle spinning of the bobbin, the tension of the bobbin thread is weakened. <ol style="list-style-type: none"> The tension of the bobbin thread too weak Both needle thread and bobbin thread tensions are too weak The presser foot and the needle plate are not suitable. 	<ol style="list-style-type: none"> Adjust the installed position of bobbin presser. Inspect the presser foot and the needle plate closely and refer to 1-2 para for adjustment. Take out the bobbin case after trimming and as you push the bobbin, try pulling out the bobbin thread. If the tension is weak, strengthen the bobbin thread tension. Make the needle thread tension stronger. Increase the pressure of presser foot. Use a bobbin case with a spring.
F. Needle thread cannot be cut (bobbin thread is cut)	<ol style="list-style-type: none"> Skip stitching at the end of sewing cycle One part of blade of trimming knife does not cut well 	<ul style="list-style-type: none"> Defective needle insertion Stroke of take-up spring too big Timing of sewing hook bad 	<ol style="list-style-type: none"> Correct the installed angle of the needle and change the curved needle. Make the stroke of the take-up spring smaller (5~7mm). Inspect the skip-stitching at low speed and correct the timing of the sewing hook (Make the timing of the sewing hook a little quicker than normal lockstitching machine).
		<ul style="list-style-type: none"> The trimming parts of moving knife and fixed knife are not sticking together at trimming time. (The angle of the fixed knife, its position and the slant of the cutting point are not matched with the cutting part of moving knife. 	<p>Remove the needle plate, and move the knife with your hand and try cutting the #50 cotton thread (3 strands at the same time). If the 3 threads are cut evenly, it's adequate but if not:</p> <ol style="list-style-type: none"> Sharpen the fixed knife blade (IV-5). Correct the inclined angle of the tip of the fixed knife (IV-5). Re-adjust the installed position of the fixed knife (IV-3).

From the library of: Superior Sewing Machine & Supply LLC

Malfunctions	Causes		Order of Inspection and Corrective Measures
G. Only bobbin thread is not cut (needle thread is cut)	3. Retreating range of moving knife insufficient	<ul style="list-style-type: none"> Inadequate adjustment of the moving knife (left-right position of the knife shaft and thread trimming cam inadequate). 	① Verify the retreating amount of the moving knife and adjust the left-right position of the trimming cam so that the retreating amount comes to 2. ~ 2.5mm (5/64" ~ 3/32").
	4. The bobbin thread position at trimming time is not steady	<ul style="list-style-type: none"> Due to using undesignated sewing hook 	① Inspect and see if the sewing hook is equipped with a bobbin thread guide groove and if not, change the sewing hook.
H. Both needle thread and bobbin thread are not cut (Stops at lowered position) 1) Even when the pedal is stepped on to the rear, sound of thread trimming magnet is not heard	1. Defective thread trimming switch components	<ul style="list-style-type: none"> Incorrect installed position of trimming switch Inadequate contact and functioning of thread trimming components Inadequate connection of the cords to the trimming components 	① Step on the pedal to the rear and verify the working sound of the thread trimming magnet. If the sound can not be heard: ② In the case of HITACHI motor, screw-in the thread trimming adjusting screw, and verify the moving sound of the switch. In the case of NATIONAL motor, exchange the switch. ③ Inspect the continuity of all parts by a tester and measure the resistance value. a. Inspect the thread trimming switch. Inspect the conductivity between the No.4(red) and No.6(blue) pin terminals of 12P plug and if at the pedal stopping position there is no conductivity but there is conductivity when the pedal is stepped to rear (thread trimming action), it is normal. When the resistance value at conductivity time is 5Ω, exchange it.
	2. Thread trimming magnet is either disconnected or shorted.		① Inspect the thread trimming magnet. Measure the resistance value between No.2(black) and No.5(brown) pin terminals of the 12P plug coming out from the machine head. a. If the resistance is 11Ω ... it is normal. * If the resistance is ∞ ... inspect the wiring and if the magnet is disconnected, exchange it. * When the resistance is 0Ω ... inspect and see if the circuit is shorted. If it is shorted inside the magnet, exchange the magnet. After that if the magnet is "ON" condition, exchange the Tr23. At this point, inspect the D33.
2) Needle stops midway before reaching the upper stop position	1. Belt is too loose		① Tighten the belt somewhat.
	2. Inadequate torque at low speed sewing	<ul style="list-style-type: none"> Voltage is too low. Faulty condition of the clutch plate of the auxiliary motor Motor lever returning spring is too weak 	① Inspect the voltage of the power source. ② Tighten the hinge nut at lever returning spring gradually, little at a time.
3) The sound of magnet is heard but the thread is not trimmed	1. Insufficient retreating range of the knife or the moving knife forked base is broken or insufficient trimming power		① Remove the needle plate and inspect and if the thread is not trimmed when thread trimming operation is performed by the pedal, it is because of insufficient retreating range of the moving knife or insufficient trimming power (IV-5, 6).
	2. The thread trimming cam and the roller do not interlock	<ul style="list-style-type: none"> The right and left position of the thread trimming cam is inadequate Faulty timing of the thread trimming cam The screws of the slide shaft collar or the cam roller arm are loose Installation of parts which are moved by the trimming magnet is faulty The knife moving shaft adjusting nut screw is loose 	① Inspect the knife driving shaft adjusting nut, slide shaft collar and the cam roller arm nut screws for loosened condition and correct them to the right positions. ② Inspect and see if the trimming arm moves smoothly until it hits the stopper within the 60° zone of the main shaft rotating angle when the needle tip slips out from the needle hole of the needle plate. If it does not move smoothly, verify first if the retreating range of the moving knife is adequate and then adjust the right and left position of the cam (IV-1). ③ Adjust the timing of the thread trimming cam with the indicating point of the hand wheel (IV-1).

Malfunctions	Causes	Order of Inspection and Corrective Measures
<p>I. Machine does not stop at the upper or lower fixed position (The stopping position of the needle is not definite)</p>	<p>1. Auxiliary driving device of the motor or the special function of the brake is not working right</p>	<ul style="list-style-type: none"> • Insufficient voltage of electrical source for the brake and auxiliary motor device or wrong connection of the disconnecting cord <ol style="list-style-type: none"> a) When connecting the electrical cord of HITACHI motor to the transformer of the control box, the method of connection is wrong b) The fuse of the control box is blown out
		<ul style="list-style-type: none"> • The magnet brake of the motor is defective
		<ul style="list-style-type: none"> • Auxiliary motor is defective
		<ul style="list-style-type: none"> • Defective bi-directional-triode thyristor
		<ol style="list-style-type: none"> ① Inspect the 6A and 1A fuses and if blown out, replace them with new ones. ② Check the voltage of the switch part and if it is normal, measure the voltage of alternate current of the transformer inside the control box. If the voltage between 0 and 31V is 25~37V, it is normal. If not, the connecting method of the input cord to the transformer is wrong, so correct it. ③ Put out all the input cords, once, and correct the insertions.
		<ol style="list-style-type: none"> ① Inspect the clearance of the magnet brake. Remove the cover of the magnet brake and adjust so that the clearance between the brake plate and the brake friction plate becomes 0.5mm. (For full details, refer to Instruction Book of Hitachi and National motors). ② Inspect the disconnection or shorting of the magnet brake. Pull out the black plugging cord inside the control box, measure the resistance between the No.3 (red lead wire) and No.4(yellow lead wire) and if it's "0" or ∞, they are disconnected or shorted and if the connection of the cords is normal, exchange the magnet brake.
		<ol style="list-style-type: none"> ① Remove the black cap of the tip of the cord coming out from the motor, remove the end cover of the motor, also, and by removing the vinyl cover of the pin terminal (3 ea. of 3 phase, 2 ea. of single phase) of the cord which is connected to the auxiliary motor and measure the conductivity of respective pin terminals by a tester. If the resistance is "0" or ∞, it means disconnection of the motor coil or shorting. (Be sure to measure the resistance within the range of R x 1. Also, the tester should measure so that when 2 test pins are contacted that they are matched to show the resistance indicator points to "0".) ② Verify that the low speed function changing pin on top of mother printed board is connected to the "ON" side. Flip up the black cap at the tip of the cord coming out from the motor, input the current (pedal is neutral and machine is stopping) and measure the voltage between the pin terminals No.1(white) and No.2(black) by means of tester AC250V range. If the voltage is over 40V, it is ok but if it's 0V, the bi-directional-triode thyristor is defective. With the 3 phase motor, measure between No.8(grey) and No.9(orange) terminals in the same manner and if not over 40V, the bi-directional-triode thyristor is defective, so in either case exchange the defective thyristor.
		<ol style="list-style-type: none"> ① When the auxiliary motor is abnormally heated, it means defective bi-directional-triode thyristor or running with defective phases (of 3 wires, 1 wire is disconnected or defective connection) ② Step on the pedal to low speed sewing and measure the voltage between No.2(black) and No.1(white) and if it's "0", it's ok and similarly if the voltage between No.8 (grey) and No.9(orange) is "0", it's ok and if any terminals show voltage of over 40V, it means defective bi-directional-triode thyristor. In such a case, exchange the thyristor. <p>(Note) The inspection of ② will be conducted with the power source in turned-on condition, so be extremely careful not to receive electric shock. Also, do not forget to set the range of the tester to AC250V.</p>

Malfunctions	Causes		Order of Inspection and Corrective Measures
		<ul style="list-style-type: none"> • Motor lever returning spring too weak or too much clearance between the worm gear of low speed rotation or brake lining of the hand wheel gear and the clutch plate 	<ol style="list-style-type: none"> ① Rotate the machine at high speed, release your foot from the pedal and at the same time lift up the motor lever and if the machine stops at this time, the above-stated spring is too weak. <ol style="list-style-type: none"> a. In the case of HITACHI motor, tighten the motor lever returning lever adjusting screw and make the spring stronger. b. In the case of HITACHI motor and NATIONAL motor, screw in the adjusting screw of the gear head part to lessen the moving range of the motor lever. ②
	2. Malfunction of sensor components	<ul style="list-style-type: none"> • Malfunction of needle positioning sensor <ol style="list-style-type: none"> a. Inadequate contact of the cord connecting the sensor to the control box or wrong connection. b. Defective connection of the electrical wiring from the control box to the transformer or inadequate plug-in of 3P connector. c. 6A and 1A fuses of the control box blown out. 	<ol style="list-style-type: none"> ① Inspect the wire connection of power source to the control box. ② Inspect and see if the fuse is disconnected or not. ③ Remove the belt of the machine from the pulley, turn over the grey cap of the 12P connector, turn the power switch on and while measuring the DC voltage between the No.1(white) and No.6(blue) terminals with the direct wire 10V range (black lead rod to No.6), rotate the pulley with the hand and if the voltage is 0V between the synchronizing zone and shows 5V at other areas, it's normal and if it's same condition between No.4(yellow) and No.6(blue), it's normal. But in either case, if the needle of the tester should remain showing 0V or 5V even once, verify the wiring connections and they are not in error, exchange them.
J. Even when the pedal is set at stopping position, the machine runs at low speed	1. Inadequate adjustment of low speed sewing switch		<ol style="list-style-type: none"> ① When the pedal is lightly stepped on and if the moving sound of the motor lever part can not be heard, adjust the position of L.SW. ② Release the plugged-in cord of the motor lever and while lowering or separating the motor lever lightly, inspect the continuity between the cords Y3(red) and Y7(grey) which come out from the motor lever. If they do not become "ON" or "OFF", exchange the switches.
	2. Connector is pulled out		<ol style="list-style-type: none"> ① Verify the plugged-in condition of the 12P connector and 9P connector (blue).
	3. Defective brake of the motor magnet		<ol style="list-style-type: none"> ① Readjust the clearance of the magnet brake. ② Inspect the wiring to magnet brake between X3 - X4 terminals. ③ Inspect the conductivity of the magnet brake of motor and if resistance is about 90Ω (Hitachi), 60Ω (National) its ok if not, ④ Exchange the magnet brake.
	4. Inadequate adjustment of stop position adjusting knob		<ol style="list-style-type: none"> ① Try to rotate the adjusting knob toward the "FAST" direction and see. ② Inspect the cord of the adjusting knob inside the control box.
K. Needle breaks at the start of sewing Unusual sound is heard from the bed part	1. Malfunction of the movement of the safety device	<ul style="list-style-type: none"> • Safety magnet cord is disconnected. 	<ol style="list-style-type: none"> ① Remove the needle, step on the pedal to rear and when the pedal is stepped on to the front quickly, verify to see if the pedal cannot be stepped on before the stopping position, (National) or becomes idle stepping (Hitachi). If it can be stepped on, adjust the safety device stopper. ② Verify and see if the moving sound of the safety magnet can be heard at the trimming time. If it cannot be heard, re-adjust the installed position of the safety lever so that the movement of the safety lever will become smooth. ③ Re-adjust the installed position of the pedal connecting rod. ④ Measure the resistance of the safety magnet. When the resistance between the terminals Y2-Y5 of the 9P plug is 0 or ∞ the connection is bad or the safety magnet is defective. (change the magnet.)

**CIRCUIT DIAGRAM FOR DDL-555-2-2, 2B
DDL-555-2-4, 4B**

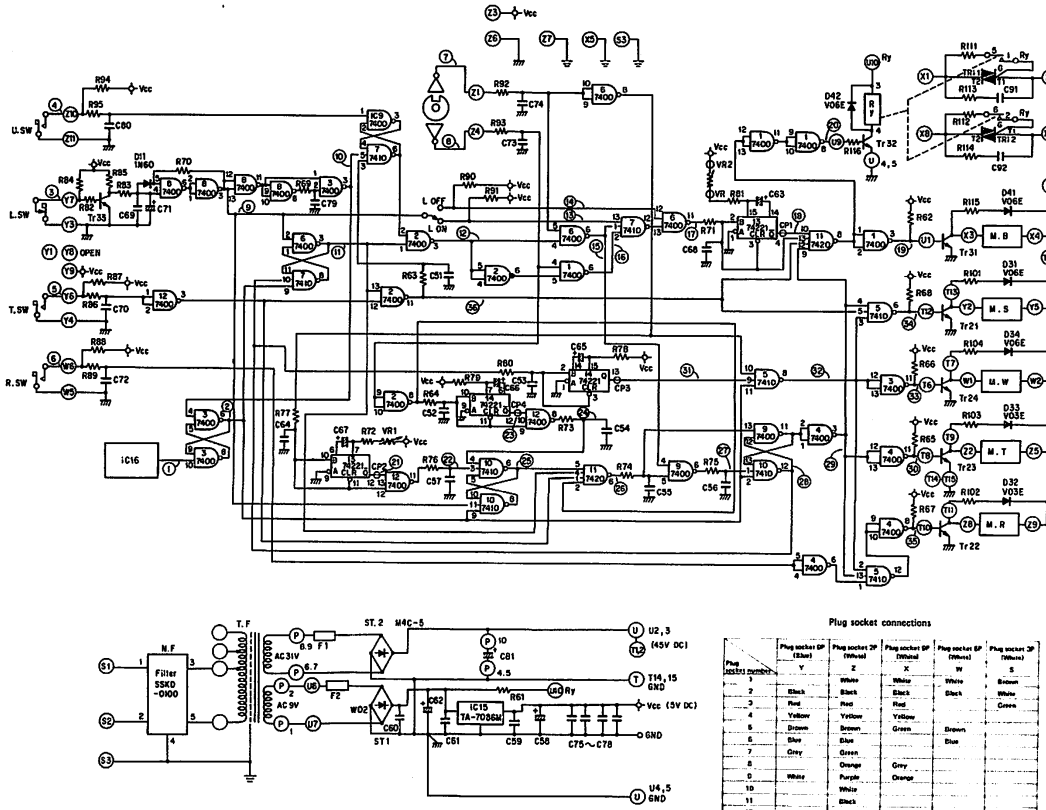

NOTE THE FIGURES IN THE CIRCLES SHOW THE TIME CHART INDICATING CODES

Plug socket connections

Plug socket SP (Ebay)	Plug socket SP (Initial)	Plug socket SP (Initial)	Plug socket SP (Ebay)	Plug socket SP (Initial)
1	Black	White	White	White
2	Black	Black	Black	Black
3	Red	Red	Red	Green
4	Yellow	Yellow	Yellow	Green
5	Green	Green	Green	Black
6	Blue	Blue	Blue	Black
7	Grey	Grey	Grey	Black
8	Orange	Orange	Orange	Black
9	White	Purple	Purple	Black
10	White	Purple	Orange	Black
11	Black	Black	Black	Black
12	Black	Black	Black	Black

Part No.	Name of part	Specifications	Part No.	Name of part	Specifications
R61	Carbon resistor	562J/2W	IC11	4 input NAND gate	SN74001
R62	Carbon resistor	470J/1/2W	IC12	2 input NAND gate	SN74001
R63-64	Carbon resistor	100J/1/2W	IC13-14	One shot multivibrator	SN74011
R65	Carbon resistor	470J/1/2W	IC15	Power regulator	LA5008
R66-68	Carbon resistor	470J/1/2W	IC16	Hybrid IC	TO221BA
R69	Carbon resistor	100J/1/2W			
R70	Carbon resistor	51J/1/2W	Tr 1-10, 23	Power transistor	2N6363CA
R71	Carbon resistor	100J/1/2W	Tr 11	Transistor	2N3638B C
R72	Carbon resistor	2K1/2W			
R73	Carbon resistor	2K1/2W			
R74-77	Carbon resistor	100J/1/2W	Tr 11-12	TRIAC	
R78-79	Carbon resistor	27K/1/2W			
R80	Carbon resistor	100J/1/2W	VR1	Small fixed variable resistor	5011
R81	Carbon resistor	2K1/2W	VR2	Variable resistor	1011 (1011P)
R82	Carbon resistor	2K1/2W			
R83	Carbon resistor	100J/1/2W	F1	Fuse	6A
R84	Carbon resistor	470J/1/2W	F2	Fuse	1A
R85	Carbon resistor	1K1/2W			
R86	Carbon resistor	100J/1/2W	ST1	Rectifier	W02G1
R87, 88	Carbon resistor	470J/1/2W	ST2	Rectifier	MAC 5
R89	Carbon resistor	100J/1/2W			
R90, 91	Carbon resistor	1K1/2W	F	Transformer	
R92, 93	Carbon resistor	100J/1/2W			
R94	Carbon resistor	470J/1/2W	N.F.	Noise suppressor A	SSD 5100
R95	Carbon resistor	100J/1/2W	N.F.	Noise suppressor D	MS 2010
R101	Carbon resistor	470J/1/2W			
R104	Carbon resistor	100J/1/2W	Tr	Relay	SAR 2776
R105	Carbon resistor	100J/1/2W			
R111, 112	Carbon resistor	100J/1/2W	D11	Diode	1N4148
R113, 114	Carbon resistor	100J/1/2W	D12, 14	Diode	1N4148
R115	Carbon resistor	470J/1/2W	D13, 16	Diode	1N4148
R116	Carbon resistor	820J/1/2W	D15, 18	Diode	1N4148
R102, 103	Carbon resistor	562J/1/2W	D14, 17	Diode	1N4148
C81	Ceramic capacitor	0.047µF 120V	C81, 82	1µF capacitor	0.25-1 400V
C82	Ceramic capacitor	0.047µF 120V			
C83-87	Ceramic capacitor	0.047µF 120V			
C88	Aluminum electrolytic capacitor	10µF 160V			
C89	Ceramic capacitor	0.047µF 120V			
C90, 91	Ceramic capacitor	0.047µF 120V			
C92	Aluminum electrolytic capacitor	220µF 160V			
C93	Tantalum electrolytic capacitor	2.2µF 160V			
C94	Ceramic capacitor	0.047µF 120V			
C95	Tantalum electrolytic capacitor	4.7µF 160V			
C96	Tantalum electrolytic capacitor	4.7µF 160V			
C97	Tantalum electrolytic capacitor	1µF 200V			
C98-10	Ceramic capacitor	0.047µF 120V			
C71	Aluminum electrolytic capacitor	33µF 100V			
C72-80	Ceramic capacitor	0.047µF 120V			
C81	Aluminum electrolytic capacitor	100µF 120V			
IC1-4	2 input NAND gate	SN74001			
IC5	2 input NAND gate	SN74001			
IC6	2 input NAND gate	SN74001			
IC7	2 input NAND gate	SN74001			
IC8, 9	2 input NAND gate	SN74001			
IC10	3 input NAND gate	SN74011			

Diagram Showing Method of Assembling Table for

JZ-D31

DDL-552-2
 DDL-553-2
 DDL-555-2
 DLN-415-2
 DLU-450-2
 DLD-432-2

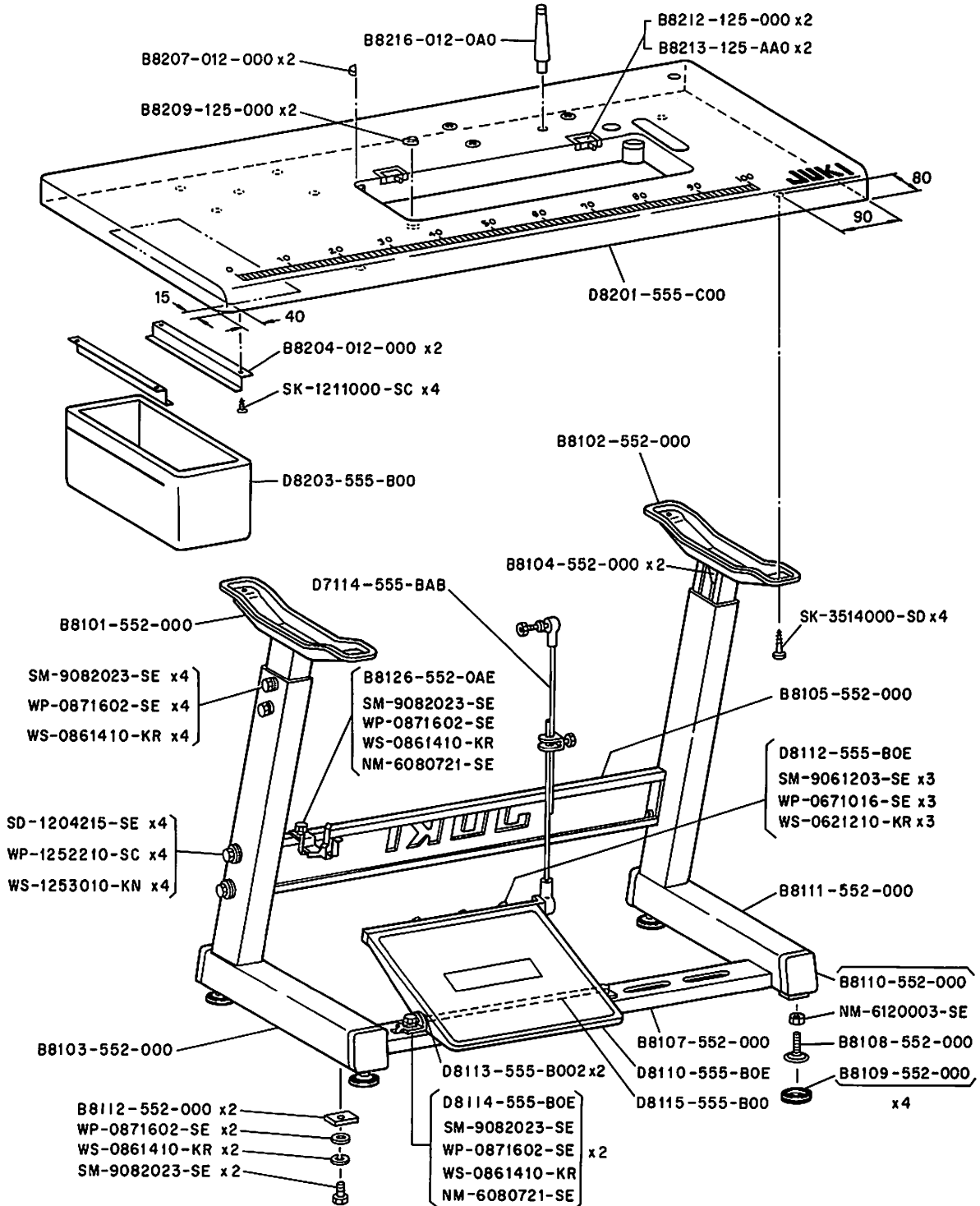

DIMENSIONAL DIAGRAM OF THE TABLE (TOP SURFACE) FOR DDL-555-2

MOTOR	A	B	C
HITACHI	105	159	66.5
NATIONAL	57	159	66.5
QUICK	80	120	70

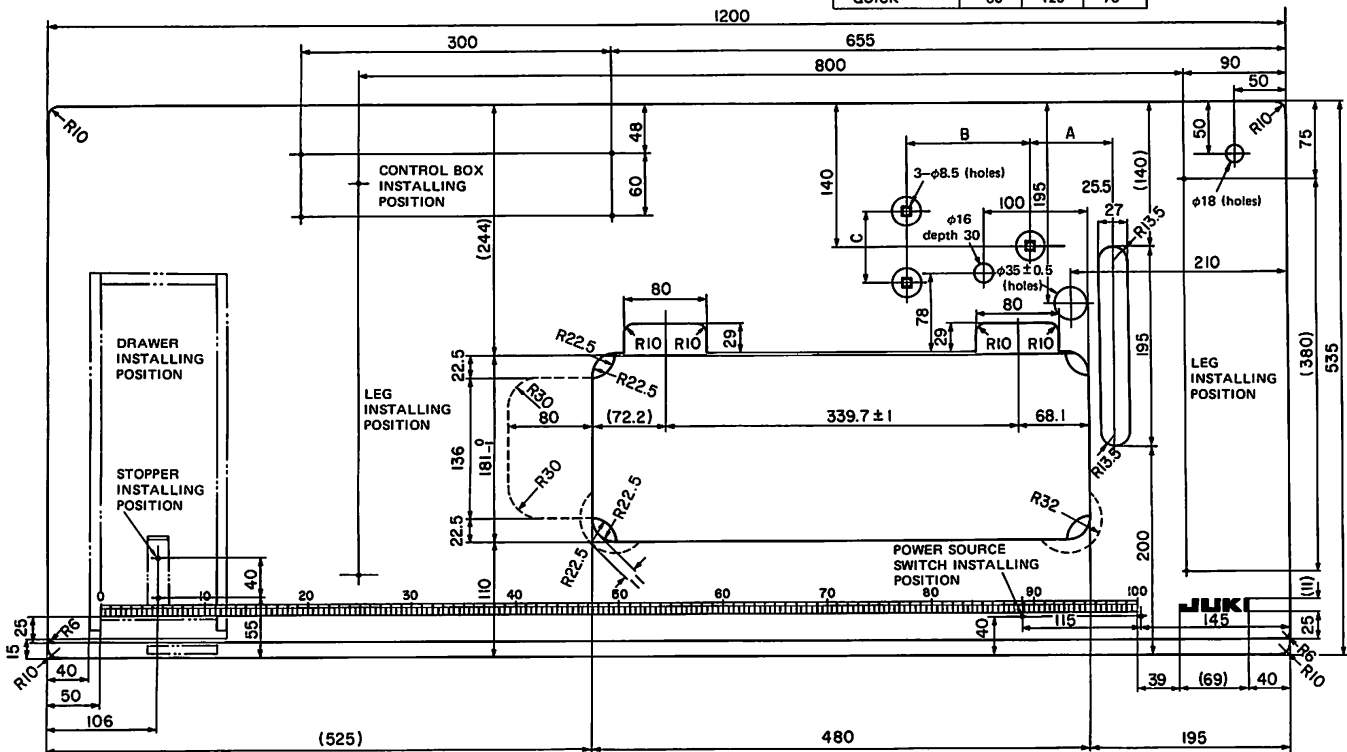

From the library of: Superior Sewing Machine & Supply LLC

MEMO

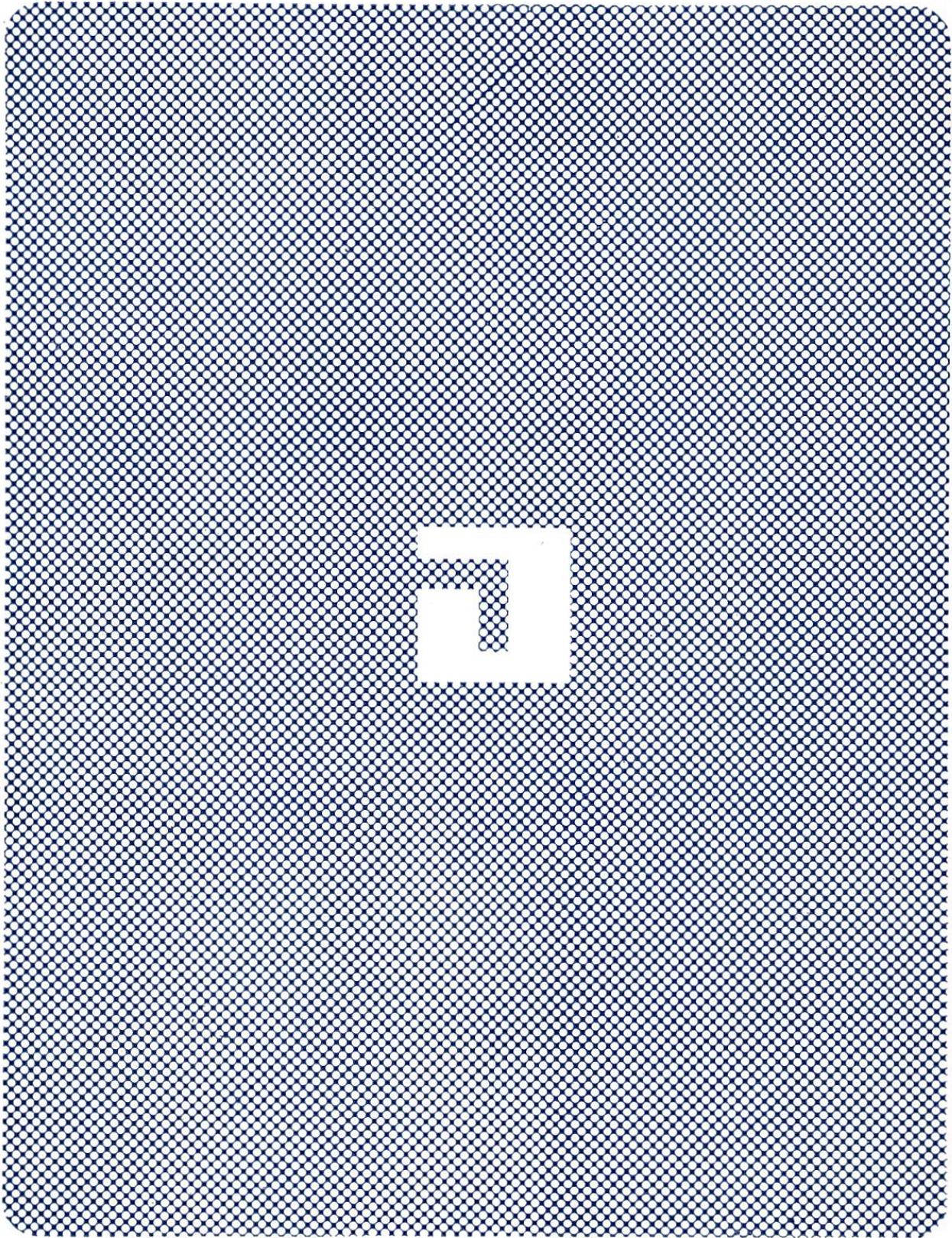

TOKYO JUKI INDUSTRIAL CO.,LTD.

Head Office & Plant, 2-1, 8-chome, Kokuryo-cho, Chofu-shi, Tokyo, Japan

Business Office, 23, Kajuku-cho, Shinjuku-ku, Tokyo, Japan

Cable Address: JUKI TOKYO Telex: 22967 JUKITK

From the library of: Superior Sewing Machine & Supply LLC

CN5553BEB Printed in Japan(T)